

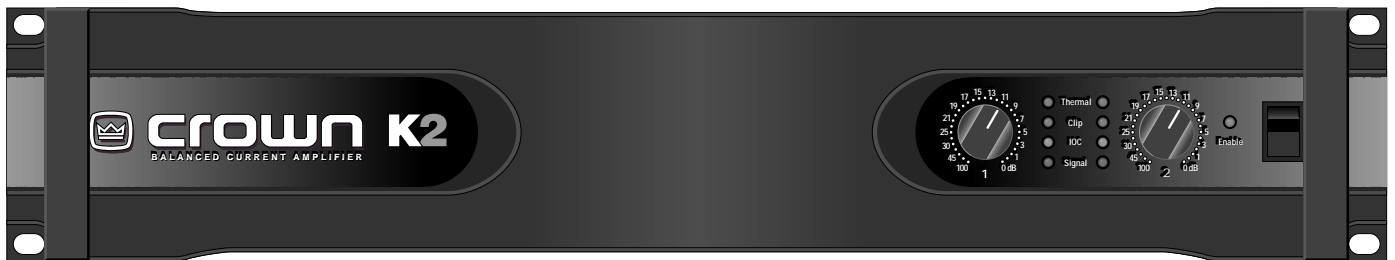

# K SERIES

## Service Manual



*PROFESSIONAL AUDIO AMPLIFIERS*

**Models:**  
**K1, K2**

© 1999 by Crown International, Inc., P.O. Box 1000, Elkhart, Indiana 46515-1000 U.S.A. Telephone: 219-294-8000. *K Series* amplifiers are produced by Crown International, Inc. Trademark Notice: *Balanced Current Amplifier™* is a trademark, and *Crown®* and *BCA®* are registered trademarks of Crown International, Inc. Other trademarks are the property of their respective owners.

KSVCK1K2  
03/98  
Rev. A

The information furnished in this manual does not include all of the details of design, production, or variations of the equipment. Nor does it cover every possible situation which may arise during installation, operation or maintenance. If you need special assistance beyond the scope of this manual, please contact the Crown Technical Support Group.

*Mail:* P.O. Box 1000 Elkhart IN 46515-1000  
*Shipping:* Plant 2 S.W., 1718 W. Mishawaka Rd., Elkhart IN 46517  
*Phone:* (800) 342-6939/(219) 294-8200  
*FAX:* (219) 294-8301  
*Web:* www.crownaudio.com

## CAUTION

**TO PREVENT ELECTRIC SHOCK DO NOT REMOVE TOP OR BOTTOM COVERS. NO USER SERVICEABLE PARTS INSIDE. REFER SERVICING TO QUALIFIED SERVICE PERSONNEL. DISCONNECT POWER CORD BEFORE REMOVING REAR INPUT MODULE TO ACCESS GAIN SWITCH.**

## AVIS

**À PRÉVENIR LE CHOC ÉLECTRIQUE N'ENLEVEZ PAS LES COUVERTURES. RIEN DES PARTIES UTILES À L'INTÉRIEUR. DÉBRANCHER LA BORNE AVANT D'OUVRIER LA MODULE EN ARRIÈRE.**



## WARNING

**TO REDUCE THE RISK OF ELECTRIC SHOCK, DO NOT EXPOSE THIS EQUIPMENT TO RAIN OR MOISTURE!**



The lightning bolt triangle is used to alert the user to the risk of electric shock.



The exclamation point triangle is used to alert the user to important operating or maintenance instructions.

# Revision History

Revision Number	Date	Changes
None	3-98	Initial Printing
Rev. A	6-99	Added Revision History, Module and Schematic Information, and Module Parts Sections. Upgraded Manual to Facilitate Component-Level Troubleshooting of PWA's. Updated Cover Page and Table of Contents.

This page intentionally left blank

# Table of Contents

<b>1 Introduction .....</b>	<b>1-1</b>
1.1 Introduction .....	1-1
1.1.1 The K Series Amplifiers .....	1-1
1.2 Warranty .....	1-1
1.3 Repair Strategy .....	1-2
1.4 Service Procedure .....	1-2
<b>2 Specifications .....</b>	<b>2-1</b>
2.1 Performance .....	2-1
2.2 Controls .....	2-1
2.3 Indicators .....	2-1
2.4 Input/Output .....	2-2
2.5 Output Signal .....	2-2
2.6 Protection .....	2-2
2.7 Construction .....	2-2
<b>3 Theory .....</b>	<b>3-1</b>
3.0 Overview .....	3-1
3.1 Power Supplies .....	3-1
3.1.1 Main Power Supply .....	3-1
3.1.2 Low Voltage Supplies .....	3-1
3.2 Input Stage .....	3-2
3.3 DC Servo .....	3-2
3.4 Sleep Circuit .....	3-2
3.5 Error Amp .....	3-2
3.6 Modulator .....	3-2
3.7 Triangle Generator .....	3-3
3.8 Proportional Vcc Generator .....	3-3
3.9 Output .....	3-3
3.10 Output Filter .....	3-3
3.11 Current Limiter .....	3-3
3.13 Overlap Correction and Adjustment .....	3-4
3.14 Display Circuitry .....	3-4
3.15 Control Circuitry .....	3-4
3.16 Crowbar Circuitry .....	3-5
<b>4 Line Voltage Conversion .....</b>	<b>4-1</b>
4.1 Line Voltage Conversion .....	4-1
<b>5 Maintenance .....</b>	<b>5-1</b>
5.1 Where to Begin .....	5-1
5.2 Disassembly for Inspection & Service .....	5-1

# Table of Contents

5.2.1 Cover Removal .....	5-1
5.2.2 Power Supply Discharge .....	5-2
5.2.3 Back Panel Assembly Removal .....	5-2
5.2.4 Front Panel Assembly Removal .....	5-3
5.2.5 Input PWA Removal .....	5-3
5.2.6 Main PWA Removal .....	5-3
5.2.7 Output PWA Removal .....	5-4
5.2.8 Control PWA Removal .....	5-4
5.2.9 Line Filter PWA Removal .....	5-4
5.2.10 Power Transformer Removal .....	5-4
5.2.11 Display PWA Removal .....	5-5
5.2.12 Bridge PWA Removal .....	5-5
5.3 Troubleshooting .....	5-6
5.3.1 Identifying Symptoms .....	5-6
5.3.2 Identifying and Repairing the Cause .....	5-6
5.4 Required Test Equipment .....	5-8
5.5 Electrical Checkout Procedures .....	5-8
5.5.1 Quiescent AC Power Draw .....	5-9
5.5.2 Gain Switches .....	5-9
5.5.3 "Y" Input Switch Operation .....	5-9
5.5.4 Bridge Mono Operation .....	5-9
5.5.5 Frequency Response .....	5-10
5.5.6 Short Circuit Test .....	5-10
5.5.7 Output Power .....	5-10
5.5.8 Intermodulation Distortion .....	5-10
5.5.9 Signal to Noise Ratio .....	5-10
5.5.10 Crosstalk at 1 kHz .....	5-10
5.5.11 Post Test Settings .....	5-11
5.6 Calibrations .....	5-11
5.6.1 Gaussian Filter Calibration .....	5-11
5.6.2 Overlap Correction and Adjustment .....	5-11
<b>6 Parts .....</b>	<b>6-1</b>
6.1 General Information .....	6-1
6.2 Ordering and Receiving Parts .....	6-1
6.2.1 Terms .....	6-1
6.2.2 Shipment .....	6-1
<b>7 Exploded View Parts .....</b>	<b>7-1</b>
7.1 General Information .....	7-1
7.2 Main Chassis Assembly .....	7-3
7.3 Front Panel Assembly .....	7-5
7.4 Back Panel Assembly .....	7-7

# Table of Contents

<b>8 Module and Schematic Information .....</b>	<b>8-1</b>
8.1 General Information .....	8-1
8.2 PWAs .....	8-1
8.3 Schematics .....	8-2
<b>9 Module Parts .....</b>	<b>9-1</b>
9.1 General Information .....	9-1
100438 PWA .....	9-2
Component Map .....	9-6
101554 Assembly .....	9-7
100469 PWA .....	9-9
Component Map .....	9-11
100497 PWA .....	9-12
Component Map .....	9-29
100524 PWA .....	9-31
Component Map .....	9-39
101014 PWA .....	9-40
Component Map .....	9-42
101809 .....	9-43
Component Map .....	9-51
101850 PWA .....	9-52
Component Map .....	9-54
101865 PWA .....	9-55
Component Map .....	9-57
102176 PWA .....	9-58
Component Map .....	9-62
102175 Assembly .....	9-63
102552 PWA .....	9-65
Component Map .....	9-67
<b>10 Schematics .....</b>	<b>10-1</b>

This page intentionally left blank



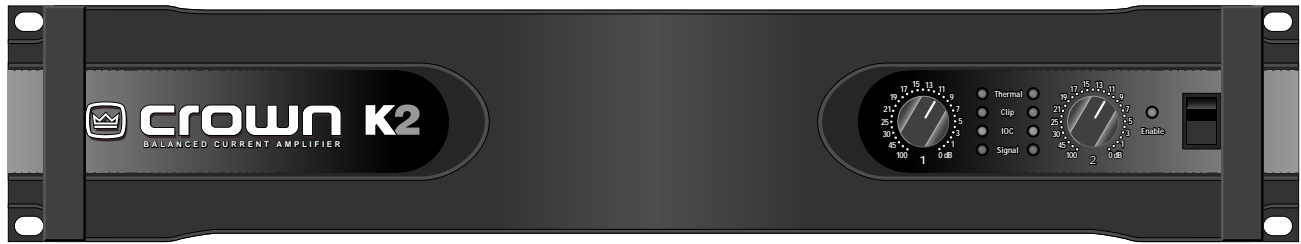

Figure 1.1 The Crown K2 Amplifier

# 1 Introduction

## 1.1 Introduction

This manual contains complete service information on the Crown K1 and K2 power amplifiers. It contains service information for both non-CE and CE (European) units. It is designed to be used in conjunction with the Reference Manual; however, some important information is duplicated in this Service Manual in case the Reference Manual is not readily available.

**NOTE: THE INFORMATION IN THIS MANUAL IS INTENDED FOR USE BY AN EXPERIENCED TECHNICIAN ONLY!**

### 1.1.1 The K Series Amplifiers

The K Series of power amplifiers are efficient, compact, high-power audio amplifiers designed for professional use. They provide full audio bandwidth, high-power amplification with minimum distortion. Crown's patented *Balanced Current Amplifier™* design allows for maintenance-free operation with maximum perfor-

mance. Other features include convection cooling, balanced inputs, Bridge-Mono operation, "Y" Input for routing one signal to both channels, and input compression for maximum loudspeaker protection.

## 1.2 Warranty

Each Reference Manual contains basic policies as related to the customer. In addition, it should be stated that this service documentation is meant to be used only by properly trained personnel. Because most Crown products carry a 3-Year Full Warranty (including round trip shipping within the United States), all warranty service should be referred to the Crown Factory or Authorized Warranty Service Center. See the applicable Reference Manual for warranty details. To find the location of the nearest Authorized Warranty Service Center or to obtain instructions for receiving Crown Factory Service, please contact the Crown Technical Support Group (within North America), or your Crown/Amcron Importer (outside North America). If you are an Authorized Warranty Service Center and have questions regarding the warranty of a product, please contact the Field Service Manager or the Technical Support Group.

### Crown Customer Service

Technical Support Group  
 Factory Service  
 Parts Department

*Mailing Address:* P.O. Box 1000, Elkhart IN 46515

*Shipping Address:* Plant 2 S. W.  
 1718 W. Mishawaka Rd., Elkhart IN 46517

Phone: (219) 294-8200

Toll Free: (800) 342-6939

Fax: (219) 294-8301

<http://www.crownaudio.com>

### 1.3 Repair Strategy

The *Balanced Current Amplifier* technology rings in a new era in Crown history. Taking full advantage of the modular design approach used in the design of *K Series* amplifiers, we are able to offer a module exchange program for this product. The concept is that the PWA (Printed Wire Assembly) as a whole is one component, and when a part of the assembly is defective, the whole assembly is defective. Exceptions are the Control, Bridge, Display, and Line Filter PWAs. Those PWAs may be repaired at the component level unless there is sufficient damage or malfunction to warrant PWA replacement. Non-PWA components are also excluded from this program.

Under the module exchange program, defective PWAs are returned to Crown for evaluation and rework. The reworked assemblies will then be stocked in the Crown Parts Department to be sold as refurbished parts.

This strategy offers several advantages. One advantage is less time spent in troubleshooting and repairing the amplifier, thus resulting in greater customer satisfaction. This strategy also allows Crown to collect the necessary information from amplifier failures, so improvements can be made for even greater product reliability.

### 1.4 Service Procedure

Servicing a *Balanced Current Amplifier* requires certain steps to be followed. See Figure 1.2 for a flow chart of these steps. It is important that the defective Printed Wire Assemblies (PWAs) be returned to Crown for evaluation and repair. Under the module exchange program, warranty claims for PWA replacement will not be honored unless the defective PWA accompanies the warranty claim. In the event of a non-warranty repair, rebuilt PWAs will be available at a lower price than new PWAs, and a discount will be given if the defective PWA is returned to Crown.

Each PWA purchased from the Crown parts department will have a tag indicating that it is "Available for Issue." This tag will have two parts. The first part simply states that the PWA is ready for use. It also has instructions for the PWA and the serial number of the module. Once the new PWA is installed, this part is to be discarded. The second part will be filled out by the service technician. After it is filled out with data such as the amplifier serial number and a description of the failure, it will be attached to the failed PWA. This part has three copies. The first is for the service center to keep. Copies 2 and 3 will remain together for use at Crown.



#### WARNING

**Component-level troubleshooting and repair of PWAs included in the module exchange program should not be attempted without expressed authorization from the Crown Audio Service Manager. Such an attempt, without specialized training and specialized test equipment, will likely result in substantial damage to the amplifier. Crown will not authorize payment of warranty claims in such an instance.**

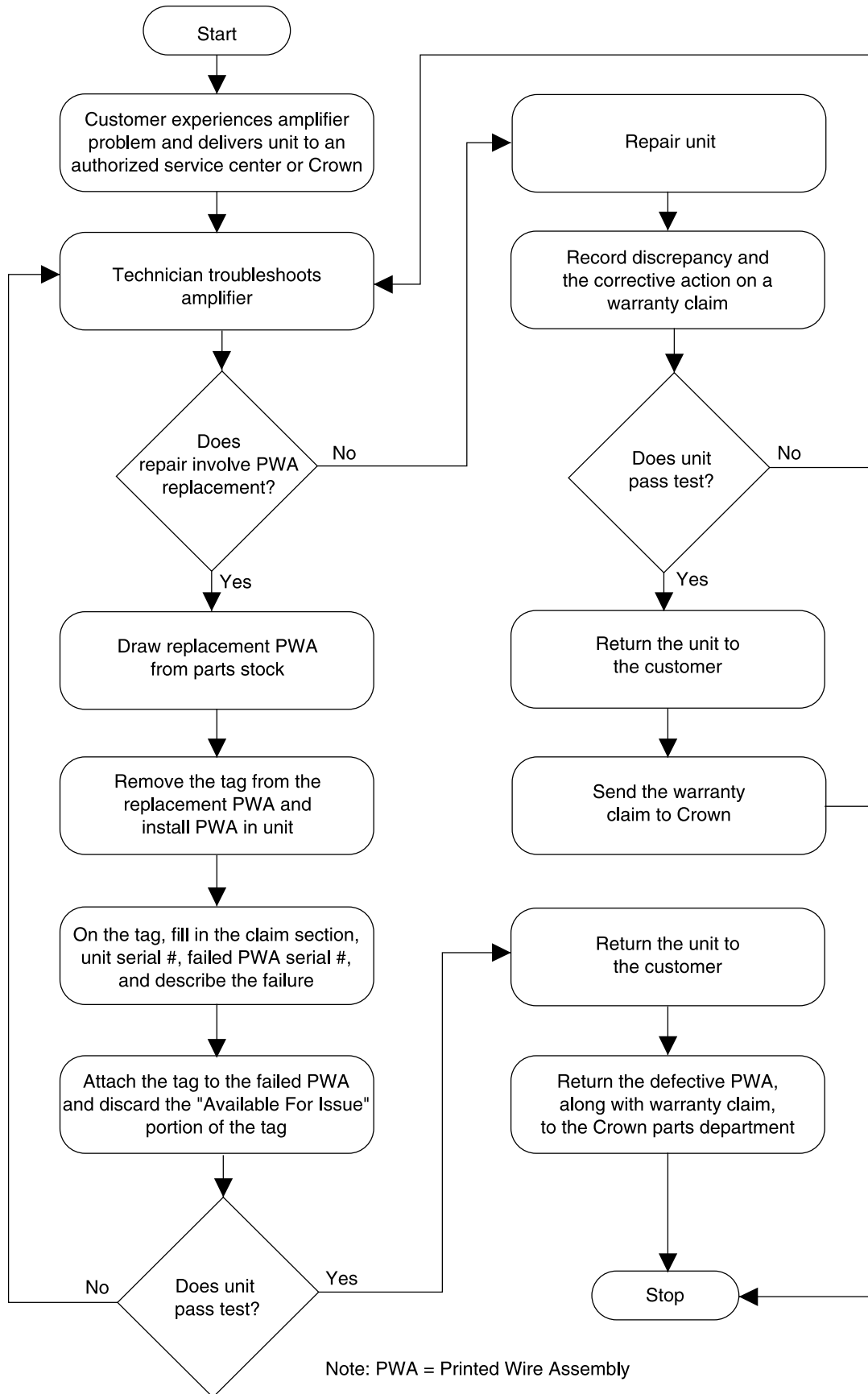

Note: PWA = Printed Wire Assembly

Figure 1.2 Service Procedure Flow Chart

This page intentionally left blank

## 2 Specifications

All specifications relate to both Export and Domestic units, regardless of voltage and frequency.

### 2.1 Performance

#### Frequency Response

±0.25 dB from 20 Hz to 20 kHz. The frequency response is band limited with an 8-Hz double-integrated 3rd-order Butterworth high-pass filter and a 30-kHz 7th-order Gaussian low-pass filter.

#### Output Power

Measured at 1 kHz with both channels driven to 0.1% or less true THD.

#### K1

2 ohm Stereo: 750 watts per channel.  
 4 ohm Stereo: 550 watts per channel.  
 8 ohm Stereo: 350 watts per channel.  
 4 ohm Bridge Mono: 1,500 watts.  
 8 ohm Bridge Mono: 1,100 watts.

#### K2

2 ohm Stereo: 1,250 watts per channel.  
 4 ohm Stereo: 800 watts per channel.  
 8 ohm Stereo: 500 watts per channel.  
 4 ohm Bridge Mono: 2,500 watts.  
 8 ohm Bridge Mono: 1,600 watts.

#### Signal-to-Noise Ratio

Greater than 100 dB below rated power, A-weighted.

#### Voltage Gain

1.4 VRMS input sensitivity or a fixed gain of 26 dB (back panel switchable).

#### Damping Factor

Greater than 3,000 from 10 Hz to 400 Hz.

#### Line Voltage Requirements

Universal power supply can be configured to operate with 100, 120, 200, 230, 240 or 250 VAC at 50 or 60 Hz.

### 2.2 Controls

#### Level

A calibrated rotary level control for each channel located on the front panel. Each control is labeled from 0 to 100 dB of voltage attenuation.

#### Power

An on/off rocker switch located on the front panel.

#### Input Sensitivity

A two-position switch for each channel, located on the back panel near each channel's input connectors. Can be set to 1.4 V for full output power into an 8-ohm load or a fixed voltage gain of 26 dB.

#### Bridge Output

An on/off switch located on the back panel between the input connectors. This switch, when turned on, bridges the two outputs with the channel one input signal.

#### "Y" Input

An on/off switch located on the back panel between the input connectors. This switch, when turned on, parallels the two input channels.

### 2.3 Indicators

#### Thermal

A red LED for each channel which turns on with a dim glow shortly before the amplifier needs help dissipating heat. The LED will turn brighter as the Thermal Level Control (TLC) protection is activated.

#### Clip

An orange LED for each channel which turns on when distortion of any type becomes audible in the amplifier output.

#### IOC

A yellow LED for each channel which serves as a distortion indicator. This indicator will light long before the distortion is audible. The IOC indicators include a pulse-stretching feature that helps make them more noticeable, even with rapid transient signals.

#### Signal

A green LED for each channel which flashes dimly when a very low-level signal (as low as 10 mW) is present in the output. They flash brightly when a louder signal (at least 1 watt) is present at the output.

#### Enable

A green LED that turns on when the amplifier has been turned on and has power. When first turned on, there will be a brief two-second delay while the amplifier performs a quick turn-on diagnostic. Then the Enable indicator will turn on to its full brightness. If no signal is present, the Enable indicator will switch to a dim level.

## 2.4 Input/Output

### Input Connectors

One balanced ¼-inch phone jack and one 3-pin female XLR connector for each channel.

### Input Stage

Input is electronically balanced and employs precision 1% resistors.

### Input Impedance

Nominally 20 K ohms, balanced. Nominally 10 K ohms, unbalanced.

### Input Sensitivity

1.4 volts for standard 1 kHz power (33 dB of gain), or 26 dB gain.

### Output Connectors

Two sets of color-coded binding posts for banana plugs, spade lugs or bare wire. European models do not accept banana plugs.

### DC Output Offset

±10 millivolts maximum.

## 2.5 Output Signal

### Stereo

Unbalanced, two channel.

### Bridge-Mono

Balanced, single-channel. Channel 1 controls are active; channel 2 should be turned down. For polarity the same as the input signal, use channel 1 output post as the speaker positive and the channel 2 output post as the speaker negative.

## 2.6 Protection

### General Protection

*K-Series* amplifiers are protected against shorted, open or mismatched loads; overloaded power supplies; excessive temperature, chain destruction phenomena, input overload damage and high-frequency blowups. They also protect loudspeakers from input/output DC, DC offset and turn-on/turn-off transients.

TLC protection circuitry protects the amplifier from excessive heat by subtly and dynamically reducing the gain only when necessary to reduce heat levels. Transformer overheating (an extremely unlikely event) will result in a temporary shutdown; when it has cooled to a safe temperature, the transformer will automatically reset itself.

Out-of-band low-pass and high-pass filters protect the amplifier and loads from infrasonic frequencies below 8 Hz and ultrasonic frequencies above 30 kHz.

### Turn On

State-of-the-art "soft start" feature prevents the amplifier from drawing a large inrush current when it is first turned on. This feature also assures that no dangerous artifacts are produced by the amplifier.

## 2.7 Construction

### Chassis

Beautiful cast-aluminum front panel coated with a durable powder coat finish. Front panel labels are printed in color on Lexan for durability and fingerprinting resistance. Aluminum chassis with durable black finish.

### Cooling

High performance passive convection cooling system allows the amplifier to drive 2-ohm loads to high music sound levels (8 dB into clip) in a 40° C environment without overthermalling.

### Dimensions

Standard 19-inch (48.3-cm) rack mount width (EIA RS-310-B), 3.5-inch (8.9-cm) height and 16-inch (40.6-cm) depth behind front mounting surface.

### Weight

#### K1

32 pounds (14.6 kg).

#### K2

38 pounds (17.3 kg).

Center of gravity approximately 6 inches (15.2-cm) behind front mounting surface and left-right centered.

## 3 Theory

### 3.0 Overview

This section of the manual explains the general operation of the K Series power amplifier. Topics covered include Power Supplies, Input Stage, DC Servo, Sleep Circuit, Error Amp, and Modulator. For simplicity, the circuit theory will only refer to channel one. It may be assumed that channel two is identical to channel one.

### 3.1 Power Supplies

There are numerous power supplies and voltage regulators found within the K Series amplifiers. The main high energy power supply and the low energy power supplies are located on the main module.

#### 3.1.1 Main Power Supply

The AC line cord is terminated through the fuse to the AC line filter circuit. C1 is a .22uF capacitor and is located across the line and neutral leads. C2 and C3 are .0047uF capacitors. C2 is connected from line to ground and C3 is connected from neutral to ground. This filter prevents unwanted emissions from contaminating the AC power line. The AC power then is routed to the control board where the power-on relay, soft start circuit and the AC line voltage configuration circuits take place.

When S1 is closed and power is first applied the relay K1 is open and current passes through PTC (R1) to the power transformer primary. The PTC restricts the amount of inrush current while the transformer is energizing. When the power supply voltage reaches operating voltage level the relay (K1) closes and bypasses the PTC resistor. D1 is a diode bridge that is configured to filter out any DC component on the AC line. This is included to eliminate the possibility of "Transformer Buzz" which can occur when a torroidal transformer is subjected to "dirty" or "noisy" AC power.

The primary wiring configuration for the multi-tap torroidal power transformer (T1) is accomplished with a connector plug that contains 9 connections. The jumpers on the plug determine the amplifiers line voltage operating level. Line voltage reconfiguration can be achieved by inserting the appropriately wired plug (See Section 4) or by rewiring the existing plug.

Full wave rectification is achieved by the bridge rectifying units D1 and D2 for the high energy supplies ( $\pm V_{cc}$ ). C5 and C7 filter unwanted AC ripple from the  $\pm V_{cc}$  power supplies.

D3, D4 and R1 detect low energy by sampling the transformer secondary voltage levels and passing this on to the Power OK circuit located on the Main module (to be covered later).

#### 3.1.2 Low Voltage Power Supplies

On power up the  $\pm V_{cc}$  power supplies first initiate. Once the +Vcc supplies are up to an operational level they power up the 125KHz oscillator: U9 and the gate driver: U10. The +Vcc is fed through F1 (3 amp fuse), L1 and R6. This sends +15V to both U9 and U10. The output of U10 is amplified by Q2, rectified by D3 and filtered by C15. The result is a regulated +15VDC. This +15V feeds U4 (+5V) which starts a 4MHz generator Y1/U6D (main schematic). The 4MHz output of U6D is sent to a divide-by chip, U5. U5 generates two outputs:

1. 500KHz—routed to the triangle generator (see Triangle generator circuit description).
2. 125KHz—routed back to the low voltage power supply. This 125KHz signal is fed back in order to drive a high frequency switch mode power supply. This SMPS consists of D4, D5, U11A, U11B, Q3 and Q4. U11A and B drive the 2 FET devices Q3 and Q4. The resulting output is a +7V 125KHz signal. The output of this switch mode power supply is routed in three directions:

1. Through C23 this supply is rectified and filtered by D10, D11, C24, and L5. The output is -13V.
2. Through C22 a 7VAC (15Vp-p) source is routed to the output stage. In the output stage T1 relays the power source to the full wave bridge (D01 and D02). Power Supply filtering is provided by C1, C2, C3 and C4. This +15V now feeds U03A and U03B (output stage FET drivers) and a +5V regulator (U01).

3. T1 Transformation:

- a. Using the primary coil of T1 the signal is filtered by C26 and L6 to supply +7V. This +7V is used to feed a number of 5V regulators found on the main module.
- b. T1 secondary #1: this power supply uses -Vcc as a reference point. The output is labeled -Vcc+12. Since the K2 Vcc is  $\pm 103V$  the output of this power supply is  $-103V + 12V = -98V$ . D12 and D13 provide rectification and C27 and C28 provide filtering.



- c. T1 secondary#2: After rectification (D14 and D15) and filtering (C29 and C30) B2+7 and B2-7
  - d. T1 secondary#3: After rectification (D16 and D17) and filtering (C31 and C32) B1+7 and B1-7
4. Oscillator Sync: the final destination of the 125KHz signal is to synchronize the original 125KHz oscillator U9.

### 3.2 Input Stage

Both XLR and phone jack input connectors are in parallel with each other. While in most audio products the incoming shield is tied to the amplifiers ground network, *K Series* amplifiers insert a 24 ohm resistor (R100) paralleled with two .01uf capacitors (C100 and C135) for the purpose of inhibiting ground loop circulating currents and RFI protection.

The signal is fed to the balanced to unbalanced gain stage. Input impedance is 20K ohm balanced and 10K ohm unbalanced.

*K Series* amplifiers come with two input sensitivity selections: 26dB and 1.4V. With the gain switch (S100) out the inverting gain stage is unity (gain of 1). With the gain switch (S100) in the inverting gain stage adds (depending on the amplifier model) the necessary gain to achieve 1.4V input sensitivity.

Inherent within all PWM amplifiers is a rise in gain at higher frequencies. Because of this a 7th order Gaussian low pass filter has been included in the input stage of the *K Series* amplifiers. This Gaussian filter is found immediately after the gain stage. U103A, U103B, U103C, U103D comprise this filter. U101D and R172 form the gain calibration stage for this 7th order Gaussian filter.

### 3.3 DC Servo

Because the K series of amplifiers are DC coupled from the Gaussian Filter through to the amplifier output DC offset voltages can appear. This DC voltage can be amplified and the audio signal ride on top shifting its reference point resulting in nonsymmetrical clipping. For this reason a DC correction circuit has been added. The non-inverting input of U105 is tied to the speaker output.

Since the purpose of U105 is to compensate for DC offset voltages elimination of any AC signal is para-

mount. There are three filters that eliminate any AC component:

1. R147 and C121 for a 1 pole filter (-3 point is 8Hz).
2. The RC networks C114/R141 and C118/R148 each form a single pole filter.

The combination of all three filters form a three-pole filter leaving only the DC voltage.

### 3.4 Sleep Circuit

The sleep circuit monitors each channel for a signal. When no signal is present for approximately six seconds the sleep circuit sends a Standby signal to the main module turning off the carrier frequency within the modulator circuit. It takes approximately 0.5mV of input signal to bring the amplifier out of Sleep mode.

Signal is sampled from the second stage (U103A pin 1) of the Gaussian low pass filter. U5D generates the Standby control signal to place the amplifier in sleep mode. R17, R15 and C7 form the RC timing network that determines the time of switching states of U5D from +0.9V (awake) and -13V (asleep). The Standby control signal is routed to the base of Q102 through the diode D111.

### 3.5 Error Amp

The audio signal enters the main module from the input module. the audio and negative feedback signals are both processed by the error amplifier U100D. From the error amplifier the signal is divided and is fed to the modulator. Since the modulator circuit is balanced the drive signal for the positive modulator is inverted by U100C.

### 3.6 Modulator

U101 and U103 are high speed differential comparators. The comparator section has two outputs: inverting and non-inverting. Therefore the output is balanced. The audio signal is applied to the inverting input of both differential comparators. The 250KHz triangle wave is applied to the non-inverting input of both differential comparators. With no audio signal the 250KHz is passed on to the NAND gate section of the differential comparator unchanged. Each NAND gate has two inputs: the modulated signal from the high speed comparator section and current limiter signal (U6A). In the event of over current the current limiter (U6A) signal is shut off disabling the NAND



gates. This results in disrupting of the signal path.

The output of U101 is balanced and forms the positive portion of the output waveform ( $V_p$ ). The output of U103 is balanced and forms the negative portion of the output waveform ( $V_n$ ). These two balanced signal lines are routed to the output stage drivers, U02 and U52.

### 3.7 Triangle Generator

The 250KHz triangle wave has its origins from the 4MHz generator. After entering the divide-by chip (U5), a 500KHz output signal (pin 9) is routed to U12B. The output of U12B is a 250KHz square wave.

The 250KHz signal is then sent through U2C. U2C is a linear IC with R186, R187, C153 and C154 in its feedback loop. This stage converts the 250KHz square wave into a triangle wave. From Pin 8 of U2C and through C152 the 250KHz triangle wave is sent to U105 which has two functions: gain and high frequency filtering. C150, C151 and R162 serve to filter the triangle wave signal.

The output of U105 is the 250KHz signal that is routed to the positive and negative modulators, U101 and U103.

### 3.8 Proportional Vcc Generator

The Proportional Vcc generator outputs a DC voltage that varies as the  $\pm V_{cc}$  levels vary. This varying DC voltage influences the 250KHz output level. Because output signal gain in a PWM amplifier can deviate as VCC varies a DC voltage proportional to the Vcc supplies is applied to the Triangle generator circuit.

U3C functions as the Proportional Vcc generator. Through a resistor dropping network (R23/R24)  $+V_{cc}$  is applied to the non-inverting input. Through another resistor dropping network (R22/R21)  $-V_{cc}$  is applied to the inverting input. On the output of U3A is a DC voltage of 6.2VDC. Through diode D21 and resistor R20 5.1VDC is applied to U12B.

### 3.9 Output

The modulated 250KHz signal exits the main module and enters output assembly by means of U02 ( $V_p$ ) and U52 ( $V_n$ ). U02 and U52 are optically coupled gates giving electrical isolation from main module cir-

cuitry. The output of U02 and U52 are then sent to the output MOSTFET drivers.

U03A, U03B, U53A and U53B are dual inverting high speed drivers designed to interface low current digital circuitry (U02 and U52) with power MOSFETs. U03A, U03B, U53A and U53B are used to drive the gates of the output FETs (Q1-Q4, Q51-Q54).

The output stage is divided into two sections, positive and negative. The signal is then routed to the BCA filter inductors ( $L_n$  and  $L_p$ ) and the current sense resistors (R13/R14 and R63/R64). The combining point is then sent to the Output Filter.

With no audio modulation both negative and positive FET stages conduct. The frequency, phase and amplitude of output FET conduction is identical. Since the FET conduction signals are the same but opposite in polarity complete cancellation takes where the BCA filter inductors and current sense resistors connect. As the fundamental center frequency (250KHz) is modulated with audio differences in frequency, phase and amplitude appear and audio output develops from the BCA filter. This signal is then routed back to the Output Filters located on the main module.

### 3.10 Output Filter

The output filter is made up of three individual filters: a 250KHz filter (L101/C127), a 500KHz filter (L102/C131) and a final 250KHz filter. The signal passes through these three filters to eliminate both any residual 500KHz and 250KHz signals. The audio signal is the connected to the output speaker connectors.

### 3.11 Current Monitor

Audio output current levels are monitored by the use of transformer T100. A small primary winding is in series with the output line and the secondary develops a voltage related to the output current of the amplifier. This output current information is used for two purposes:

1. Negative feed back.
2. Current feedback information for the Triangle wave generator.

### 3.12 Current Limiter

To prevent excessive output current the K series am-

plifiers are incorporated with a current limiting protection circuit. The output current is sense by the current sense resistors found in series with the BCA filter inductors. The voltage dropped across these two resistors is sent back to U106A and U106B. The voltage windows for U106A and U106B are set by the dropping resistors R303/R310 and the zener diodes D113/D114. The window voltage is  $\pm 0.7V$ . The outputs of the window comparator are normally  $+0.6V$ . This positive voltage is sent to U107A, an optically coupled gate. Pin 2 of U107A is tied to B1-7 and as long as pin 1 is positive the device conducts. The output is an inverting stage so when its input is positive its output will be negative. If the current limit detector switches states (becomes negative) pin 1 is negative and pin 7 becomes positive.

The output of U107A is routed to U6A (exclusive NOR) and as long its inputs are negative the output of U6A will be positive allowing the modulating network (U101 and U103) to output signal. If the output of U107A goes positive the output of U6A goes negative thus disabling the modulating circuit.

### 3.13 Overlap Correction and Adjustment

The Overlap adjustment corrects for DC shift in the Triangle waveform. In order to track thermal variations the Overlap adjustment potentiometer (R25) is located on each of the Output assemblies. A positive DC voltage is routed from the wiper arm of R26 to the Triangle wave gain stage. This DC voltage varies the DC component of the 250KHz waveform.

### 3.14 Display Circuitry

The *IOC* (Input Output Comparator) circuit uses the error signal from the error amplifier (U100D). With a window of  $\pm 0.3V$  U102A and U102D have a positive output. This in turn biases off D105 leaving a positive voltage on the base of Q103. If an error signal appears the  $\pm 0.3V$  window is overcome and the combined outputs become negative. This results in the output of U102C to go negative and in turn biasing on Q103. As Q103 biases on, E102 illuminates.

A sample of the amplifier output (Fo CH1) is sent to U2A and U2B. This audio waveform sample then drives Q102 varying the current to the SPI (Signal Presence Indicator) LED E101.

The compressor circuit is initiated by either the *IOC* initialization signal or The Thermal Limit Control sig-

nal. When initialized U1B output (pin 7) becomes positive. After routed through the non-inverting input of U1A this positive signal turns on E100.

The signal used to switch on the Power LED comes from the Power OK control circuit. As this line goes positive Q1 conducts lighting E1.

### 3.15 Control Circuitry

After initial power supply power up the outputs of U7C and U7D become positive ( $+1.2V$ ). The output of U7C and U7D is routed to two places: 1.) the first is the Power OK LED and 2.) then the Modulator enable/disable comparator, U108A.. This positive logic signal causes the output of U108A to become positive ( $+1.3V$ ) which next biases on Q102. With Q102 biased on the collector/emitter voltage is low ( $0.6V$ ). Since U6A is a NOR gate and both inputs are low the output is a logic high allowing the modulator circuits (U101 and U103) to pass signal.

There are four functions that can disable the modulator circuit and disable the amplifier. These four inputs all effect the control line connected to pin 5 of U108A. The normal logic levels for this control line are: ON/ $0.6$  and OFF/ $-14$ ). The four control functions are:

1. Initial Turn On Delay (U8A). On initial turn on the control line to U108A is logic low causing the modulator to be disabled. Once the capacitor found within the RC timing network (C161/R302) charges this comparator stage switches states allowing the Modulator to conduct. (Normal logic levels are ON/ $0.6$  and OFF/ $-14$ ).
2. Over Temperature (U108B). In the event the amplifier overheats the output of U108B switches states disabling the Modulator.
3. Proportional Vcc (U8C). The Proportional Vcc circuit monitors the  $\pm Vcc$  power supplies. In the event that the line voltage drops to far below the rated line voltage (causing erratic operation) U8C switches states disabling the Modulator circuit.
4. Current Limit (U108D).

If the amplifiers current limit is exceeded because of low impedances or a short circuit loading, U108D switches states and disables the modulator circuit.

### 3.16 Crowbar Circuit

U13B and U13C form the DC protection comparator circuitry. R191, R192 and C156 form a combination resistive dividing and low pass filter networks. Signals below 8Hz (including DC voltages) cause the combined outputs to become a logic low (-14V). This logic level is inverted by the next comparator stage, U7B. a logic high (0.6V) causes Q10 to conduct. Once U7B switches states (logic high) U7A inverts this logic level and latches the Fault circuit in the Crowbar disabled condition. In order to clear this latched state the amplifier must be first turned off.

When the amplifier is turned on the line current conducts through the R1 (power supply circuit diagram) until the relay energizes. The relay primary is energized when Q8 is biased on. Q8 is biased on when Q7 is biased off (high collector/emitter voltage). When the relay closes R1 is bypassed allowing full power supply energy available to the output stage. If Q10 conducts Q7 is biased on and Q8 is biased off. This disables the power input relay.

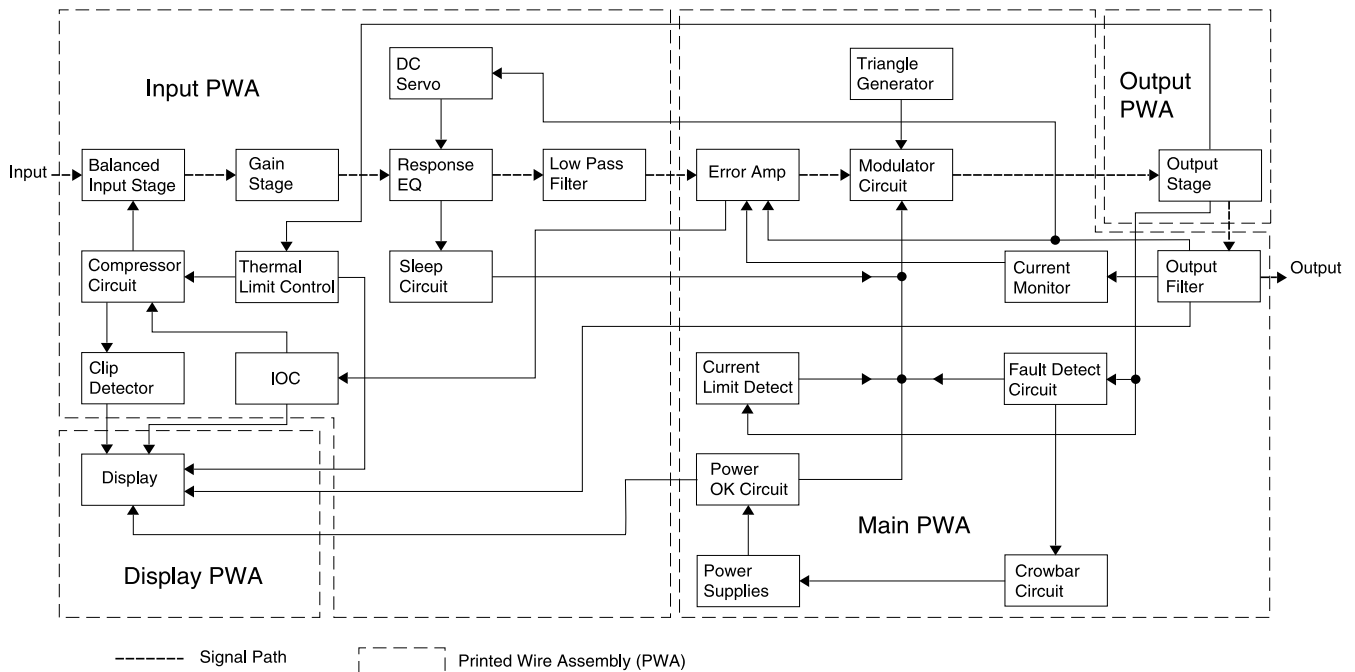

Figure 3.1 Amplifier Block Diagram

This Page Intentionally Left Blank

# 4 Line Voltage Conversion

## 4.1 Line Voltage Conversion

The *K Series* amplifier can be configured to operate at any line voltage in the world. It is also made to operate at 50- or 60-hertz frequency with no modification. To convert from one line voltage to another, change the Voltage Plug (P7), a 9 pin connector plug on the Control PWA. Refer to Figure 4.1 for the Crown Part Number of the plug you need. These plugs are available from the Crown Parts Department.

The Voltage Plugs have jumpers installed which configure the primary power transformer windings for the

appropriate operating voltage. Figure 4.1 has information on jumper location for each voltage.

When wiring the molex connector the proper insertion and removal tool should be used (example, Amp #458994-2).

When converting from the 100V range to the 200V range, or vice versa, be sure and change the back panel line fuse. The fuse values and Crown Part Numbers are listed in Figure 4.1.

For your reference, Figure 4.2 shows the Control PWA, P7, and the pin configuration of P7. To access the Control PWA, remove the bottom cover of the amplifier. The Control PWA is located in the center of the chassis. For additional information on disassembly and assembly of the amplifier refer to Chapter 5.

Voltage	100V	120V	130V	200V	220V	230V	240V	250V
Plug Part #	101230-1	101231-1	NA*	NA*	101232-1	101233-1	101234-1	NA*
Voltage Plug Jumpers	5-7 6-2 3-4	5-8 6-1 3-4	1-8 3-4 5-9	2-4 5-7	2-4 5-8	2-4 5-9	1-4 5-8	1-4 5-9
Fuse	K1: A10285-27, 15A K2: A10285-28, 20A			K1: A10285-40, 8A K2: A10285-26, 10A				

\* Voltage Plug not available. Voltage may be obtained by positioning the jumpers as indicated. The Crown Part Number for the Voltage Jumper Wire is A11555-P025P. The Crown Part Number for the 9-Pin Molex Connector is C10303-3.

Figure 4.1 Line Voltage Selection Table

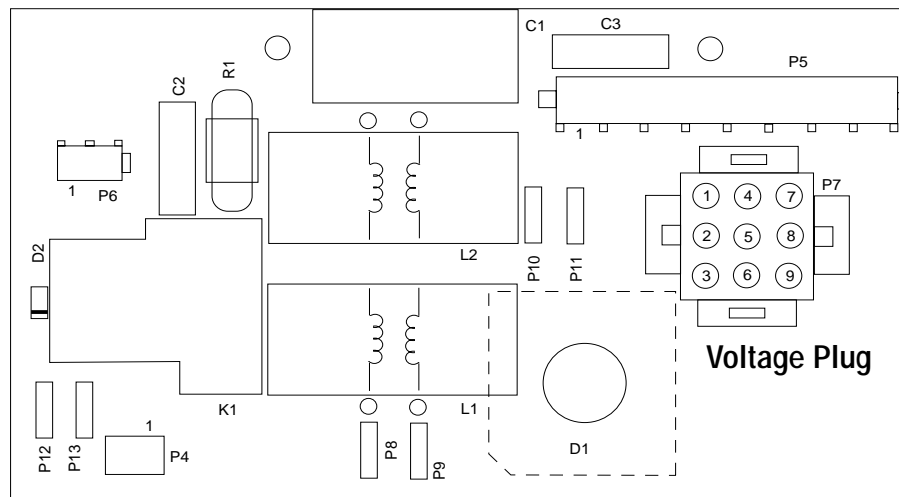

Figure 4.2 Control PWA with Voltage Plug

This page intentionally left blank

## 5 Maintenance

### 5.1 Where to Begin

Effective repair involves three basic steps: 1) Determine the symptom(s) of the problem; 2) Identify the cause(s) of the symptom(s); 3) Repair the unit to eliminate the cause(s). To determine the symptoms, you will want to get as much information from the user as possible. Get as much information as you can about the system and how the amplifier is used. There is always the possibility that the problem will show up only if used in a specific way.

Once you have all the information about the symptom(s), it is time to inspect the amplifier. A careful visual inspection is valuable for most problems which you may encounter. To inspect the inside of the amplifier remove the cover as described in Section 5.2.1.

Begin the inspection by looking for anything which appears abnormal, like loose connectors, broken wires and burnt or visibly damaged components. Inspect the printed circuit assemblies for broken traces and loose connections. Be thorough. The time you spend visually inspecting the amp is time well spent.

### 5.2 Disassembly for Inspection & Service

The extent of disassembly required will depend upon the extent of inspection and service required.

**NOTE: TO AVOID THE RISK OF ELECTRIC SHOCK, TURN OFF AND UNPLUG THE AMPLIFIER FROM THE AC POWER OUTLET BEFORE DISASSEMBLY OR REASSEMBLY IS ATTEMPTED.**



#### 5.2.1 Bottom Cover Removal

To remove the cover of the amplifier you will need a #15 torx bit (TX15). After the cover is removed, and before any internal cables are disconnected, **discharge the supplies**. See Section 5.2.2.

1. Turn the amplifier on its side on your workbench. The only access to the inside of the amplifier is the bottom cover.
2. Using the TX15 bit, remove the 14 screws around the perimeter of the cover.
3. The cover lifts straight up after the screws are removed.
4. Vacuum out any metal particles in the unit that are a result of the lock washers digging into the chassis.

The cover on early units may appear to be symmetrical but it's not. When installing it onto the unit, make sure there is no gap between the front edge of the cover and the lip of the front panel extrusion. If installed backwards, there will be an 1/8-inch gap at the front, and an 1/8-inch overhang out the back of the unit.



#### WARNING

Amplifier components are ESD sensitive. When servicing the amplifier, the technician must have approved ESD protection. Proper grounding straps and test equipment are required. Failure to use proper protection will result in component failure.



#### WARNING

Before unplugging or plugging in any connectors or wires in the amplifier, discharge the power supplies. See section 5.2.2 for instructions. Failure to do so will result in circuit failure.

### 5.2.2 Power Supply Discharge

Before any connectors and PWAs are removed, the Power Supplies need to be discharged. Follow these simple steps.

1. Make sure the amplifier is unplugged from the AC power source.
2. Locate Test Point 1 (TP1) on the Main PWA. See Figure 5.1.
3. With a flat blade screwdriver or another metal object, short TP1 to the nearest resistor pad. This resistor is the second one from the end of a row of seven 3W resistors. Once the short is made you do not have to hold the screwdriver in place. The initial short triggers a latching triac circuit which discharges the supplies.
4. Wait a few seconds before attempting to disassemble the amplifier.



**Caution: the three-watt resistors will become hot as the power supplies discharge.**

### 5.2.3 Back Panel Assembly Removal

The back panel assembly is removed to access the Input and Main PWAs.

1. **Follow the instructions in Section 5.2.2. Supply discharge is necessary to avoid circuit damage.**
2. Remove the aluminum shield by removing the two screws on the rear and the one on the control board.

Note: This shield is not used on early non-CE units.

3. Using a TX15 bit, remove the two screws on each side of the amp that hold the rear supports. See Figure 5.2. **Item A**

4. Remove the five TX15 screws along the top rear of the amplifier.

**Caution: These screws are shorter than the other cover screws and must be reinstalled in the same location or Main PWA will be shorted to chassis.**

5. Remove the two TX15 screws on the Main PWA. See Figure 5.2. **Item B**

6. Unplug the black and white wires (P8 & P9) and the ribbon cable (P4) from the Control PWA. See Figure 5.2. **Item C**

7. Unplug the P1 ribbon cable from the Input PWA. See Figure 5.2. **Item D**

8. Unplug the main wiring harness from the Main PWA. See Figure 5.2. **Item E**

9. Remove the necessary tie wraps and unplug the ribbon cables from the Output PWAs. See Figure 5.2. **Item F**

10. Gently slide the back panel assembly straight out the back of the amplifier. Note that the PC cards slide in the rails formed in the aluminium heatsink. Be careful of the wires and cables that will come with the assembly.

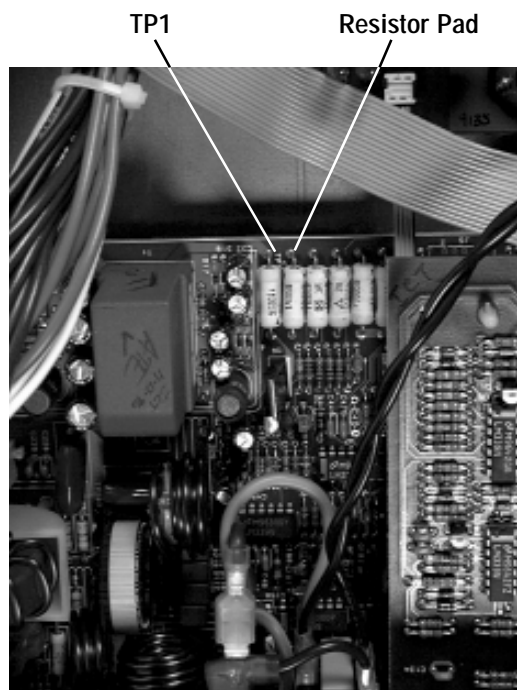

Figure 5.1 Discharge Test Point



### 5.2.4 Front Panel Assembly Removal

The front panel assembly is removed to access the Power Switch, Display PWA, Bridge PWA and the Power Transformer.

1. **Follow the instructions in Section 5.2.2. Supply discharge is necessary to avoid circuit damage.**
2. Using a TX 15 bit, remove two screws on each side of the amp located directly behind the rack ears. See Figure 5.2. *Item G*
3. Remove the four TX 15 screws along the top front of the amplifier.
4. Unplug the main wiring harness from the Bridge PWA. See Figure 5.2. *Item H*
5. Remove the P1 ribbon connector from the Input PWA. See Figure 5.2. *Item D*
6. Remove the P5 and P6 transformer wire connectors, and P10, P11, P12 and P13 switch wires from the Control PWA. See Figure 5.2. *Item I*
7. The Front Panel Assembly will now come off of the amplifier. Pull on the front panel handles while securing the chassis of the amplifier. Be careful of the wires and cables that will come with the assembly. When reinstalling the Front Panel, make sure the capacitors on the Bridge PWA clear the aluminum heat sink and the Output PWA.

### 5.2.5 Input PWA Removal

The Back Panel Assembly must be removed to gain access to the Input PWA.

1. **Follow the instructions in Section 5.2.2. Supply discharge is necessary to avoid circuit damage.**
2. Remove the P2 ribbon cable from the Input PWA.
3. Using a #1 Phillips bit, remove the four screws that hold the two female XLR jacks on the back panel.
4. Using a  $\frac{5}{8}$ -inch nut driver, remove the two plastic nuts that hold the  $\frac{1}{4}$ -inch input jacks in place.
5. Using a TX15 bit, remove the two screws on the back panel that hold the Input PWA in place.
6. Locate the plastic board stand-off between the Main and Input PWAs. Using your fingernail or pliers, press the release tab on the stand-off while gently lifting the Input PWA off the stand-off.
7. While guiding the input jacks out of the holes in the back panel, slowly lift the PWA out of the assembly.

### 5.2.6 Main PWA Removal

The Back Panel Assembly must be removed to gain access to the Main PWA.

1. **Follow the instructions in Section 5.2.2. Supply discharge is necessary to avoid circuit damage.**

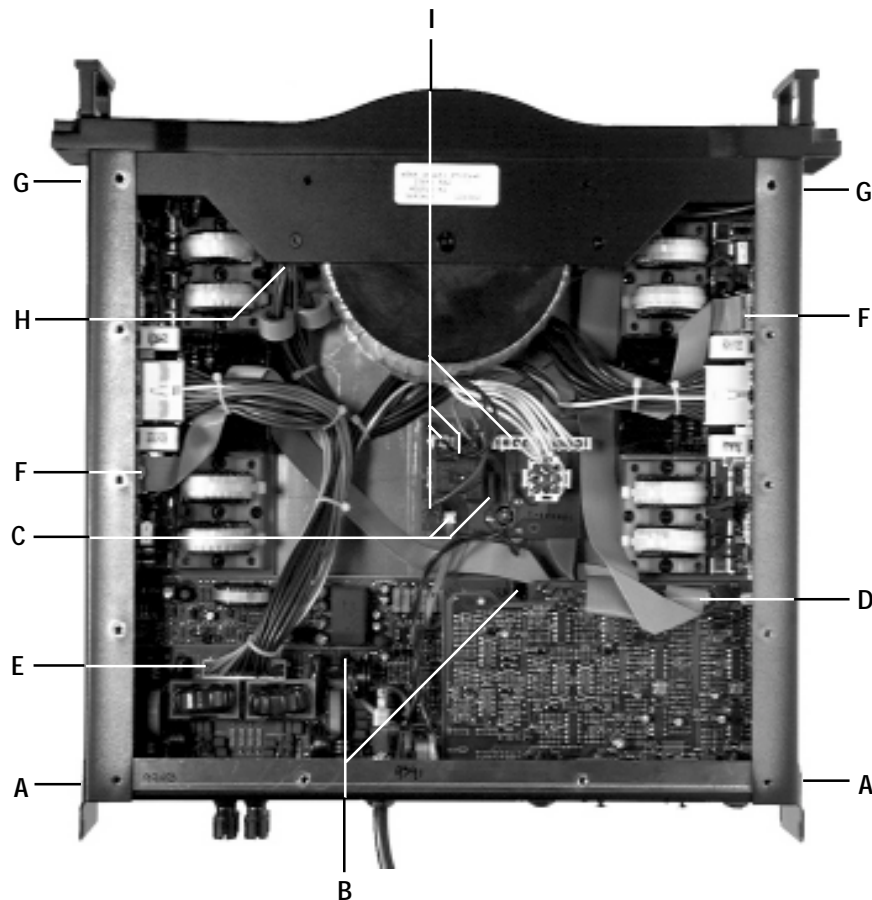

Figure 5.2 Bottom View

2. Remove the P2 ribbon cable from the Input PWA.
3. Using a needle nose pliers, unplug the six red wires that go to the positive output binding posts. Note where they go.
4. Using a TX15 bit, remove the three screws that secure the Main PWA to the back panel.



**Caution: Do not power up the amplifier without replacing these screws, or circuit damage to the Output PWAs will occur.**

5. Locate the plastic board stand-off between the Main and Input PWAs. Using your fingernail or pliers, press the release tab on the stand-off while gently separating the two PWAs.
6. Lift the Main PWA away from the back panel. When installing the Main PWA onto the Back Panel Assembly be careful not to bend the capacitor located under the Line Filter PWA. If the unit is an early non-CE unit, the clearance between a capacitor on the Line Filter and a capacitor on the Main PWA is very small.

### 5.2.7 Output PWA Removal

The left and right Output PWAs are identical.

1. **Follow the instructions in Section 5.2.2. Supply discharge is necessary to avoid circuit damage.**
2. Unplug the P01 ribbon connector and the P3 wiring harness connector from the Output PWA.
3. Using a TX15 bit, remove the screw located at the center-top of the assembly. See Figure 5.3. **Item A.**
4. Using a TX20 bit, remove the six screws located by the four large coils on the assembly. See Figure 5.3. **Item B**

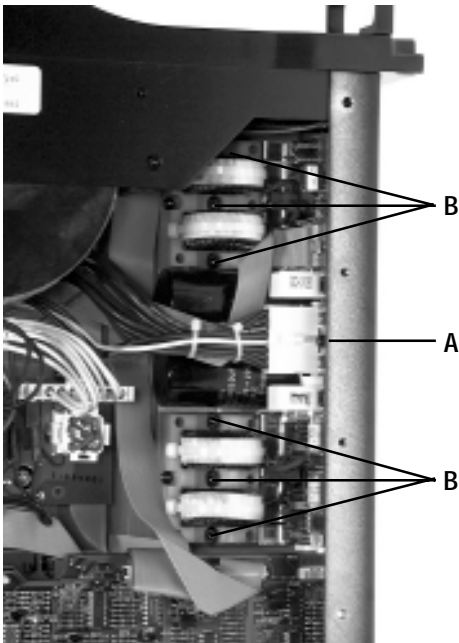

Figure 5.3 Output PWA Screws

Be very careful not to damage the coils with your screwdriver. Note that the screws have Belleville washers on them. When replacing the screws be sure the cupped side of the washer is down toward the assembly.

5. Carefully lift the assembly out of the chassis. When reinstalling the Output Assembly use a new insulator pad and make sure there are no metal shavings on the pad or the heatsinks. Any metal shavings will result in a "blow-up" when the unit is first turned on. To be sure that the insulator is free of shavings, and is installed correctly, use an Ohm Meter to check for continuity between the assembly heatsink and the chassis. There should be no continuity.

### 5.2.8 Control PWA Removal

1. **Follow the instructions in Section 5.2.2. Supply discharge is necessary to avoid circuit damage.**
2. Remove EMC shield on all but early non-CE units.
3. While noting where each wire goes, disconnect each connector on the Control PWA. The white wire goes on P9, and the black wire on P8. The two orange wires go on P10 and P11. The two purple wires go on P12 and P13.
4. To remove the Bridge Rectifier (D1) along with the PWA, use an  $1\frac{1}{32}$ -inch (.86 cm) nut driver to remove the nut. If you wish to leave the Bridge installed to the chassis then desolder the four rectifier pads.
5. Using a TX15 bit, remove the three screws that hold the Control PWA in place.
6. Lift the Control PWA out of the chassis.

If replacing the PWA with a new one, be sure and remove the Voltage Plug (P7) and install it on the new PWA.

If replacing the Bridge Rectifier, be sure and use thermal heatsink compound between the rectifier and the chassis.

### 5.2.9 Line Filter PWA Removal (Early non-CE Units Only)

1. **Follow the instructions in Section 5.2.2. Supply discharge is necessary to avoid circuit damage.**
2. While noting where each wire goes, disconnect each wire from the PWA. The blue power cord wire goes on P4. The long black wire goes on P1, the white on P2. The short black wire from the fuse goes on P3.
3. Using a TX15 bit, remove the two screws that attach the assembly to the back panel.
4. Lift the Line Filter PWA out of the chassis.

### 5.2.10 Power Transformer Removal

The Front Panel Assembly must be removed in order to remove the Power Transformer.

1. **Follow the instructions in Section 5.2.2. Supply discharge is necessary to avoid circuit damage.**

2. Clip the tie wrap which holds the orange and purple wires to the Transformer Bracket.
3. Unplug the white wires from the Bridge PWA (P11, P12 and P13). Note that the white wire with the black ring attaches to P12.
4. Using a TX15 bit, remove the two screws which hold the Transformer Bracket to the Front Panel.
5. Using a TX25 bit, remove the bolt which goes through the center of the transformer. The plastic bracket can now be removed.
6. While carefully lifting the transformer out of the front panel, route the white wires underneath the Bridge PWA. The transformer will now lift free of the front panel.

### 5.2.11 Display PWA Removal

The Front Panel Assembly must be removed in order to remove the Display PWA.

1. **Follow the instructions in Section 5.2.2. Supply discharge is necessary to avoid circuit damage.**
2. The two level control knobs on the front panel are press fit onto the shafts. Remove these knobs.
3. Using a  $\frac{7}{16}$ -inch nut driver, remove the nuts on the level control shafts. Also remove the flat washers.

4. Lift the Display PWA out of the Front Panel Assembly.

### 5.2.12 Bridge PWA Removal

The Front Panel Assembly must be removed in order to remove the Bridge PWA.

1. **Follow the instructions in Section 5.2.2. Supply discharge is necessary to avoid circuit damage.**
2. Unplug the white transformer wires from the PWA. Note that the white wire with the black ring goes to P12.
3. Using a T20 bit, remove the two screws that hold the bridge rectifiers to the front panel. The screws have bellville washers. When installing the screws with the washers, make sure the cupped side of the washer is toward the bridge.
4. Using a T20 bit, remove the screw in the center of the PWA.
5. The bridge assembly will now lift out of the front panel. When installing it back into the front panel, make sure there is thermal heatsink compound between the bridges and the front panel.

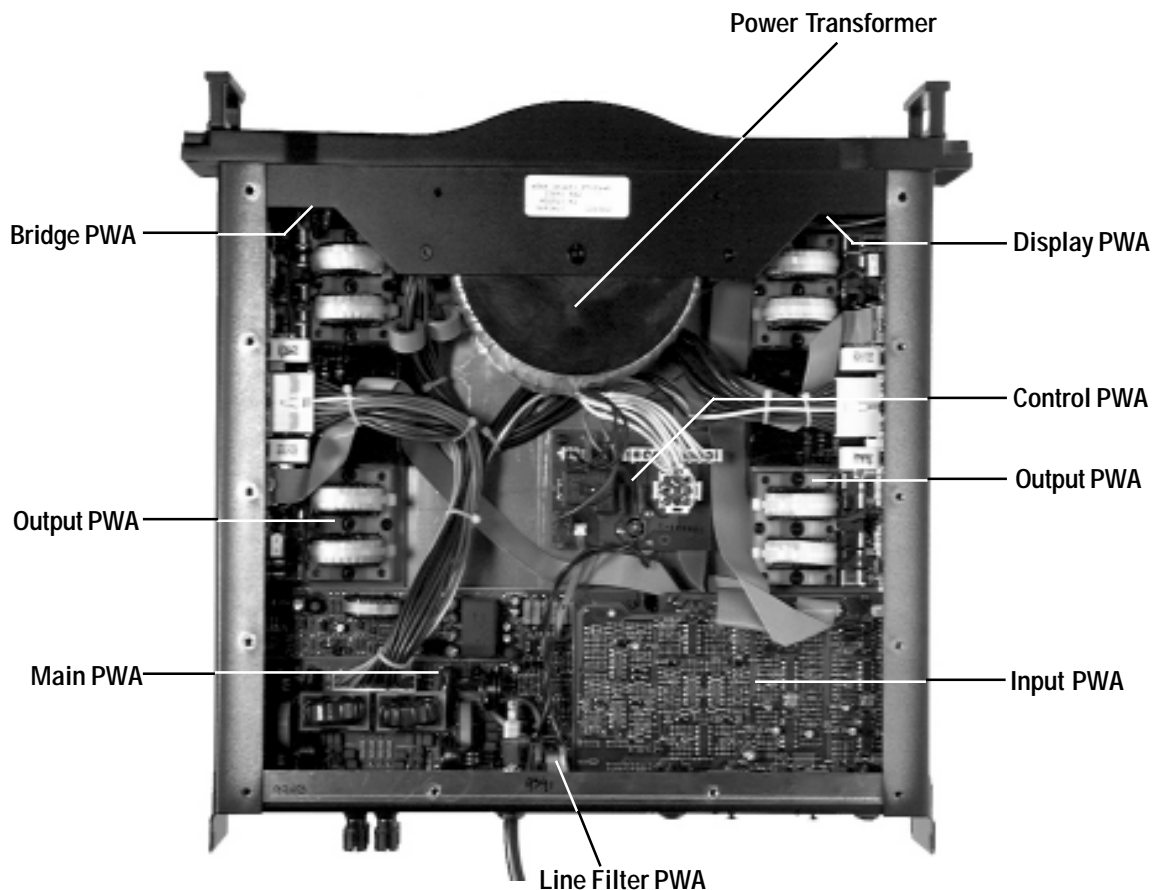

Figure 5.4 PWA Layout

## 5.3 Troubleshooting

As mentioned earlier, the three steps to effective repair are: Determine the symptoms; identify the cause of the symptoms; repair the unit to eliminate the cause.

The purpose of this section is to help you through these steps in an orderly manner.

### 5.3.1 Identifying Symptoms

Why was the amplifier brought in for repair? Can you get it to malfunction again? Some problems can be intermittent and difficult to find.

Once you have identified and verified the symptoms, you can look for helpful information in Section 5.3.2 as to where the cause of the problem is located.

If you don't observe anything wrong with the amplifier, tactfully inquire how the owner used it and try to determine if it was misused or some other component in their system could have been at fault. Remember that the protection circuits in this amplifier will protect loudspeakers from problems caused upstream from the amplifier (DC protect).

If you lack sufficient information about the problem, and there aren't any obvious problems with the amplifier, skip to Section 5.4, the Electrical Checkout Procedures.

### 5.3.2 Identifying and Repairing the Cause

The first step in identifying the cause of the problem is always a visual inspection. Once the bottom cover is removed, and the supplies are discharged, look for loose connectors, broken wires, loose hardware, burnt components, or bad solder joints on the PC boards. Any burnt components are a sure sign that the PWA will need to be replaced.

Once the visual inspection is complete you may proceed in powering up the unit. The best way to positively locate which PWA is at fault is to have a working PWA of each type on hand and plug them into the amplifier one at a time to see when the problem goes away. Output and Input PWAs can be plugged into the amplifier easily without removing the old PWA. When doing so, use an insulating material to isolate it from the chassis and other PWAs. The Main PWA, however, needs to be installed into the chassis before it can be properly hooked up.

The following Symptoms and Causes may help you determine which corrective action to take. We realize that this list is limited. Please read through the Theory chapter in this manual to better understand the function of each PWA. This will help you come to your own conclusion as to the location of the problem.

#### **Amp does not appear to power up. No Enable light.**

First, check the power supply fuse. Also, make sure the AC line voltage is correct for the amplifier you are working on. Severely low AC line voltage could cause the amp to not power up. If both check out, then the amplifier is in a fault mode. The two most likely areas are the Main PWA or an Output PWA.

First, check the Output PWAs. **Discharge the supplies**, then disconnect the main wiring harness (P3) from the PWA in question. Now power up the unit. After the delay, if the enable light comes on, the disconnected Output PWA needs to be repaired or replaced.

To check if the Main PWA is at fault **discharge the supplies**, then unplug only one Output PWA from the main wiring harness (P3), and unplug the Input PWA (P2) from the Main PWA. Now apply power and check the +15VDC and the -13VDC. To do this, locate U7 on the Main PWA (next to where the Input PWA overlaps



### **WARNING**

**Before unplugging or plugging in any connectors or wires in the amplifier, discharge the power supplies. See section 5.2.2 for instructions. Failure to do so will result in circuit failure.**



the Main PWA). Using the chassis as the ground reference, pin 3 is +15VDC and pin 12 is -13VDC. If the both voltages are correct, discharge power supplies, then plug Output PWA back in, and unplug the other Output PWA. Repeat test. If one or both of the DC voltages is not correct then repair or replace the Main PWA.

**No Signal; one or both channels. Enable on. IOC on.**

A constant IOC condition indicates a problem in the signal path including the Error Amp circuit. This includes the Main and Output PWAs. The problem most likely exists on the Main PWA.

**No Signal; one or both channels. Enable light only.**

The problem most likely exists on the Input PWA. If the Input PWA proves to not be the problem then the Main PWA is at fault.

To check the Input PWA, inject a signal into the channel at fault and turn the level control up. Locate U103 (Ch1) or U203 (Ch2). With an oscilloscope check to see if there is signal at pin 8. If there is no signal at this point **discharge the supplies**, then repair or replace the PWA. If there is signal then check U5 pin 13 with a DC volt meter. If this pin is at -13VDC then the signal detect circuit is not working. **Discharge the supplies**, then repair or replace the Input PWA. If you find signal at U103/203 pin 8, and U5 pin 13 is high (0 VDC), then the Input PWA is OK. **Discharge the supplies**, then repair or replace the Main PWA.

**Distortion; one or both channels. IOC indication.**

The problem most likely exists on either the Output PWA or Main PWA. Check the Output PWA first. If the Output PWA checks out, repair or replace Main PWA.

**Distortion; one or both channels. No IOC.**

The problem most likely exists on the Input PWA. First check levels on affected channels, no load. If levels check out, **discharge the supplies**, then repair or replace Input PWA.

**Amplifier does not meet power specs.**

Check your power source. If the AC voltage sags below the specified operating voltage of the amplifier then the unit will not produce full rated output.

The large power supply filter capacitors located on the Output PWAs are wired in parallel from one PWA to the other. If one or more of these capacitors has a broken solder joint it could result in the amplifier not meeting power specifications. To check the capacitors, **discharge the supplies**, then remove the Output Assembly. Wiggle the capacitors back and forth. If they appear to be loose then they are bad. Repair or replace

Output PWA.

Check the Main Wiring Harness. Multiple wires are used in parallel to handle the high supply currents. If one or more of these wires is broken then it will result in restricted current. This could result in the amplifier not meeting power specifications.

**Frequency Response out of tolerance.**

The problem most likely exists on the Input PWA. The Input PWA has the EQ circuit for a flat response. If this circuit is faulty the amplifier will have poor frequency response. **Discharge the supplies**, then repair or replace Input PWA.

**Voltage gain problems.**

If you experience voltage gain problems with no distortion, the problem most likely exists on the Input PWA. The Input Sensitivity/Gain Stage circuitry is located on the Input PWA. **Discharge the supplies**, then check the Input PWA. If it is faulty, repair or replace PWA. If Input PWA checks out, the problem is likely on the Display PWA, which includes the Level Control Pots. **Discharge the supplies**, then check Display PWA. If Display PWA is faulty, repair or replace PWA.

If you have gain problems with distortion, resulting in an IOC condition, then the problem most likely exists on the Main PWA. **Discharge the supplies**, then check Main PWA. If faulty, repair or replace PWA.

**Amplifier gets extremely warm at idle.**

Sleep Mode is indicated on the front panel by the Enable indicator. When it switches to half intensity then the amplifier is in sleep mode. It takes approximately 6 seconds after the signal is removed before the amplifier goes into Sleep Mode. Note that any signal at all, even a small one, will keep the amplifier out of sleep mode and it will get warm to the touch. If, with no signal at all, the amplifier never goes into Sleep Mode then the problem most likely exists on the Input PWA. The Signal Detect circuit for Sleep Mode is located on the Input PWA. **Discharge the supplies**, then check Input PWA. If faulty, repair or replace PWA.

To verify the operation of the Signal Detect Circuit, locate U5 on the Input PWA. Monitor pin 13 with a DC volt meter referenced to chassis ground. If it switches to -13VDC 6 seconds after signal is removed then the circuit is OK. If this circuit is OK, but the amplifier never goes to Sleep, then the problem exists on the Main PWA. **Discharge the supplies**, then repair or replace Main PWA.

**Amplifier consistently trips breakers at turn on.**

A Soft Start circuit on the Control PWA limits the amount

of inrush current at turn on. Check the PTC (R1) on the Control PWA. It should measure approximately 5 ohms. If it is shorted then replace it. Another possibility is that the relay (K1) has failed.

If the amplifier trips breakers and you can never get it powered up, **Discharge the supplies**, then check the bridge rectifiers (D1 and D2) at the Bridge PWA located in the Front Panel Assembly.

**DC output offset**

If there is an IOC indication, the problem most likely exists on the Main PWA. **Discharge the supplies**, then check the Main PWA. if faulty, repair or replace PWA. If there is no IOC condition then the problem is on the Input PWA. **Discharge the supplies**, then repair or replace Input PWA.

**Signal to noise out of spec.**

If the ribbon cable between the Display and Input PWA is not routed properly it can cause high Signal to Noise.

It needs to be lying down and away from the large coils on the Output PWA. The coils can induce noise into the ribbon cables.

**Turn on/off transient**

The problem is most likely on the Input PWA. The only real way of verifying this is to plug a working Input PWA into the amplifier and see if the problem goes away. If it is not the Input PWA, it is probably the Main PWA. The amplifier should be silent at turn-on and turn-off.

**5.4 Required Test Equipment**

Due to the complex circuitry utilized the the K Series amplifiers, special calibration procedures and the correct test equipment are necessary to insure original factory specifications are achieved. Following is list of test equipment needed to successfully service the K Series amplifier. Recommended models are those used by Crown:

Device	Requirements	Recommended Model
Oscilloscope	* 500 MHz or greater	LeCroy 9354A
Distortion Analyzer	THD and IM measurements	Audio Precision ATS-1
DC Power Supplies	* 103 VDC with I-Limiting and * 12-15 VDC with I-Limiting	Leader 760-3D (Qty. 2) Leader 18-3D
Function Generator		Hewlett-Packard HP 33120A
AC/DC volt meter	* dB reading capability	Hewlett-Packard HP 34401A
Dummy Loads	8 ohm, 550 watt, 4 ohm, 850 watt, and 2 ohm, 1300 watt	

\* Requirement for component-level troubleshooting only

## 5.5 Electrical Checkout Procedures

The test procedures in this section are used to verify the operation of the amplifier. You may, however, find these tests helpful in troubleshooting a problem if the problem is not easily identified.

All tests assume that AC power is from a regulated source at the voltage the amplifier is set up for. See Chapter 4 if you need to change the operating voltage.

Test equipment includes an oscilloscope, a DMM, a signal generator, loads, watt meter, I.M. distortion analyzer, and a true THD meter.

During each test, it is assumed that the following conditions are set on the amplifier unless otherwise noted:

- Level controls fully clockwise.
- Bridge Output switch off.
- "Y" Input switch off.
- Input Sensitivity of both channels set at 26 dB.

### 5.5.1 Quiescent AC Power Draw

Spec: 100 watts maximum quiescent. 10 watts in sleep mode.

Procedure: With no load connected to the amplifier, turn on the amplifier. Inject a small signal into one of the inputs to keep the amplifier out of sleep mode. Measure AC power draw. It should be less than 100 watts. Remove the signal from the amplifier and wait approximately 6 seconds for the amp to go into sleep mode. Measure AC power draw. It should be 10 watts  $\pm 3$  W.

### 5.5.2 Gain Switches

Spec: 1.4 V, 26 dB

K1 Procedure: No Load. With the level controls at full gain and the input sensitivity switches set to 1.4 V, inject a 1 kHz, 0.775 Vrms, into each channel. At the output of each channel measure 29.3 Vrms,  $\pm 0.9$  Vrms. Switch the Input Sensitivity switches to 26 dB. Measure 15.3 Vrms,  $\pm 0.6$  Vrms, at the outputs.

K2 Procedure: No load. With the level controls at full gain and the Input Sensitivity switches set to 1.4 V, inject a 1 kHz, 0.775 Vrms, into each channel. At the output of each channel measure 34 Vrms,  $\pm 1.3$  Vrms. Switch the Input Sensitivity switches to 26 dB. Measure 15.3 Vrms,  $\pm 0.6$  Vrms, at the outputs.

### 5.5.3 "Y" Input Switch Operation

Spec: Channel 1 input will produce an output at both channels. Both outputs will be in phase.

Procedure: No load. Switch the "Y" Input switch on. Inject a 1 kHz sine wave into channel 1 only. You should see output on both channels. They should be in phase with each other. With the gain switches set the same, and the level controls both at full volume, you should see the same output voltage at both channels. Remove the signal and turn the "Y" Input switch off.

### 5.5.4 Bridge Mono Operation

Spec: Same voltage out both channels, channel 2 out of phase.

Procedure: No load. Switch the Bridge Mono switch on and inject a 1 kHz sine wave into channel 1 only. Monitor both outputs of the amplifier. They should be the same voltage and out of phase with each other. Remove the signal and turn the Bridge Mono switch off.



## WARNING

**Before unplugging or plugging in any connectors or wires in the amplifier, discharge the power supplies. See section 5.2.2 for instructions. Failure to do so will result in circuit failure.**

### 5.5.5 Frequency Response

Spec:  $\pm 0.25$  dB from 20 Hz to 20 kHz.

Procedure: Load the channel under test to 4 ohms. Inject a 0.1Vrms, 1kHz sine wave into the input. Measure the output voltage. It should be 2.0 Vrms. This is now your 1 kHz reference voltage. Switch the frequency to 20 Hz and verify that the input voltage is still 0.1 Vrms. Measure the output voltage. It should

be the same as the 1 kHz reference voltage  $\pm 0.25$  dB. Switch the frequency to 20 kHz and verify that the input voltage is still 0.1 Vrms. Measure the output voltage and compare it to the 1 kHz reference voltage. Tolerance is  $\pm 0.25$  dB. Remove the load and signal. Note: Many oscillators need a frequency check at 20 kHz.

### 5.5.6 Short Circuit Test

Spec: Amplifier will protect itself

Procedure: Inject a 1kHz, 1Vrms sine wave into the input of channel 1. Short the output of channel 1 to ground for 10 seconds. The amplifier should cycle into fault mode. Every two seconds the Clip and IOC lights will flash, indicating that it is checking to see if the short is still there. Remove the short and perform the test on channel 2.

### 5.5.7 Output Power

K1 Spec: Each channel    350 watts into 8 ohms  
                                   550 watts into 4 ohms  
                                   750 watts into 2 ohms

K2 Spec: Each channel    475 watts into 8 ohms  
                                   800 watts into 4 ohms  
                                   1250 watts into 2 ohms

Measure less than 0.1% true THD.

K1 Procedure 8 ohm: Load the channel under test to 8 ohms. Inject a 1kHz sine wave and bring the level up until the output reaches 0.1% TRUE THD. Measure at least 52.9 Vrms at the output.

K1 Procedure 4 ohm: Load the channel under test to 4 ohms. Inject a 1kHz sine wave and bring the level up until the output reaches 0.1% TRUE THD. Measure at least 46.9 Vrms at the output.

K1 Procedure 2 ohm: Due to the duty cycle of a test signal, the line fuse will blow if both channels are tested at the same time. When testing 2-ohm power, test one channel at a time. Load the channel under test to 2 ohms. Inject a 1kHz sine wave and bring the level up until the output reaches 0.1% TRUE THD. Measure at least 38.7 Vrms at the output.

K2 Procedure 8 ohm: Load the channel under test to 8 ohms. Inject a 1kHz sine wave and bring the level up until the output reaches 0.1% TRUE THD. Measure at least 61.6 Vrms at the output.

K2 Procedure 4 ohm: Load the channel under test to 4 ohms. Inject a 1kHz sine wave and bring the level up until the output reaches 0.1% TRUE THD. Measure at least 56.6 Vrms at the output.

K2 Procedure 2 ohm: Due to the duty cycle of a test signal, the line fuse will blow if both channels are tested at the same time. When testing 2-ohm power, test one channel at a time. Load the channel under test to 2 ohms. Inject a 1kHz sine wave and bring the level up until the output reaches 0.1% TRUE THD. Measure at least 50.0 Vrms at the output.

### 5.5.8 Intermodulation Distortion

Spec: Less than 0.2% from 0 dB to -35 dB.

Procedure: Load the channel under test to 8 ohms. Inject a SMPTE standard IM signal (60 Hz and 7 kHz mixed at 4:1). Adjust the output voltage for a peak equivalent voltage of 60.0 volts (K1) or 70.0 volts (K2). This is your 0-dB reference. Measure less than 0.2% IMD from 0 dB to -35 dB in 5-dB steps.

### 5.5.9 Signal to Noise Ratio

Spec: Greater than 100 dB below rated 8 ohm power, A weighted.

Procedure: Load the channel under test to 8 ohms. Terminate the input with 600 ohms. Verify that the gain switch is set at 26 dB and level control is at full volume. Measure less than 529  $\mu$ Vrms (K1) or 616  $\mu$ Vrms (K2) at the output using an A-weighted filter.

Note: Due to the power conservation circuit you only have 6 seconds to do this test after a signal is injected. After a signal is used, quickly remove the signal and measure Signal to Noise.

### 5.5.10 Crosstalk at 1 kHz

Spec: Greater than 90 dB.

Procedure: Load each channel to 8 ohms. Verify that both gain switches are set at 26 dB and both level controls are at full volume. Inject a 2.5 Vrms, 1 kHz, sine wave into channel 1 and terminate channel 2 with 600 ohms. Measure less than 1.58 mV at the output of channel 2. Now remove the signal from channel one and inject it into channel 2. Terminate channel 1 with 600 ohms. Measure less than 1.58 mV at the output of channel 1.



### 5.5.11 Post Test Settings

After completion of testing, if all tests are satisfactory, the amplifier controls should be returned to the positions required by the customer. If the conditions are unknown or unspecified, the factory settings are as follows:

- Gain switches set to 1.4 V
  - Bridge Mono switch turned off
  - “Y” Input switch turned off
  - Level controls at 0 dB
  - Power switch turned off

## 5.6 Calibrations

**These calibrations should only be performed by those servicers authorized to do component-level repair of PWAs included in the module exchange program (see Section 1.3).**

### 5.6.1 Gaussian Filter Calibration

Procedure 1: Obtain a multimeter with decibel measurement capabilities. Set the multimeter to dB measurement mode. Insert a 1Khz signal into the input and measure at pin 8 of U103C. Reset the meter to 0dB using the 1KHz signal as a reference signal. Increase the signal generator frequency to 20KHz, leaving the output level unchanged. While measuring pin 8 of U103C adjust R172 for a reduction of level by 2.6dB (readout should be -2.6dB).

Procedure 2: Obtain a multimeter with decibel measurement capabilities. Set the meter to dB measurement mode. Insert a 1Khz signal into the input and measure at the speaker output (no load). Reset the meter to 0dB using the 1KHz signal as a reference signal. Increase the signal generator frequency to 20KHz, leaving the output level unchanged. Adjust R172 for a meter reading of 0db. This second test method is an alternative to the first and should give the desired results: a flat frequency response throughout the audio bandwidth.

### 5.6.2 Overlap Correction and Adjustment

Conditions:

- Amplifier output assembly MUST be room temperature (72 degrees F/21 degrees C)
- No input signal
- No load

Procedure: Monitor TP51 found on the Output Assembly. Center oscilloscope to view lower right portion of waveform. Adjust R25 on each Output PWA for sharpest squarewave edges (see Figure 5.1). Figure 5.2 shows “Underlap” (under adjustment). Figure 5.3 shows “Overlap” (over adjustment). If too much time is taken

to perform this procedure the Sleep circuit may cause the amplifier to go into standby. A brief input signal (no load) will bring the amplifier out of Sleep mode.

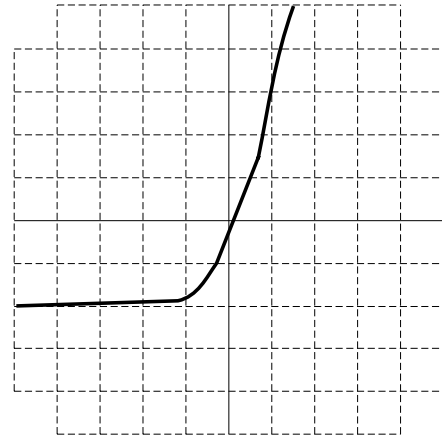

Figure 5.1 Correct Overlap Adjustment

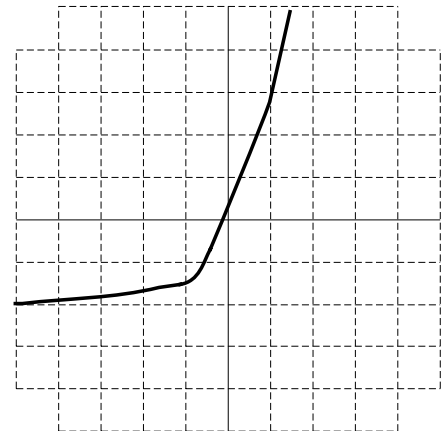

Figure 5.2 Underlap

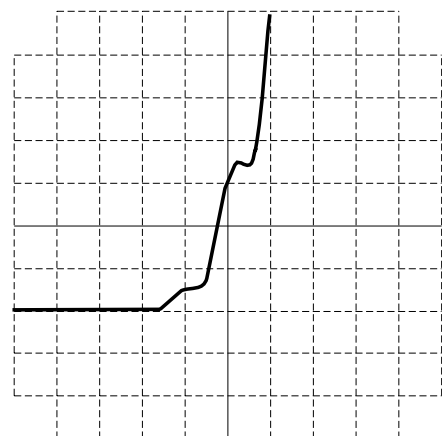

Figure 5.3 Excessive Overlap

This page intentionally left blank

## 6 Parts

### 6.1 General Information

This chapter includes both a mechanical and electrical parts list for this product. All serviceable parts and assemblies will have a Crown Part Number (CPN) listed in this chapter. The parts listed are current as of the date printed. Crown reserves the right to modify and improve its products for the benefit of its customers.

Crown is not a general parts warehouse. Parts sold by the Crown Parts Department are solely for servicing Crown/Amcron products.

**Part prices and availability are subject to change without notice.**

### 6.2 Ordering and Receiving Parts

When ordering parts, be sure to give the product model, and include a description and part number from the parts listing. Price quotes are available on request.

#### 6.2.1 Terms

Normal terms are prepaid. Net-30 Days applies to only those having pre-established accounts with Crown. The Crown Parts Department does accept Visa or Master Card. If prepaying, the order must be packed and weighed before a total bill can be established, after which an amount due will be issued and shipment made upon receipt of payment. New parts returned for credit are subject to a restocking fee, and authorization from the Crown Parts Department must be obtained before returning parts for credit.

#### 6.2.2 Shipment

Shipment will normally be made via UPS, or best other method unless you specify otherwise. Shipments are made to and from Elkhart, Indiana USA, only. Established accounts with Crown will receive shipment freight prepaid and will be billed. All others will receive shipment on a C.O.D. or prepayment (check or credit card) basis.

### Crown Customer Service

Technical Support Group  
Factory Service  
Parts Department

*Mailing Address:* P.O. Box 1000, Elkhart IN 46515

*Shipping Address:* Plant 2 S. W.

1718 W. Mishawaka Rd., Elkhart IN 46517

Phone: (219) 294-8200

Toll Free: (800) 342-6939

Fax: (219) 294-8301

<http://www.crownaudio.com>

This Page Intentionally Left Blank

---

## 7 Exploded View Parts

---

### 7.1 General Information

This chapter includes a mechanical part list for this product. All serviceable parts and assemblies will have a Crown Part Number (CPN) listed in this chapter. The parts listed are current as of the date printed. Crown reserves the right to modify and improve its products for the benefit of its customers.

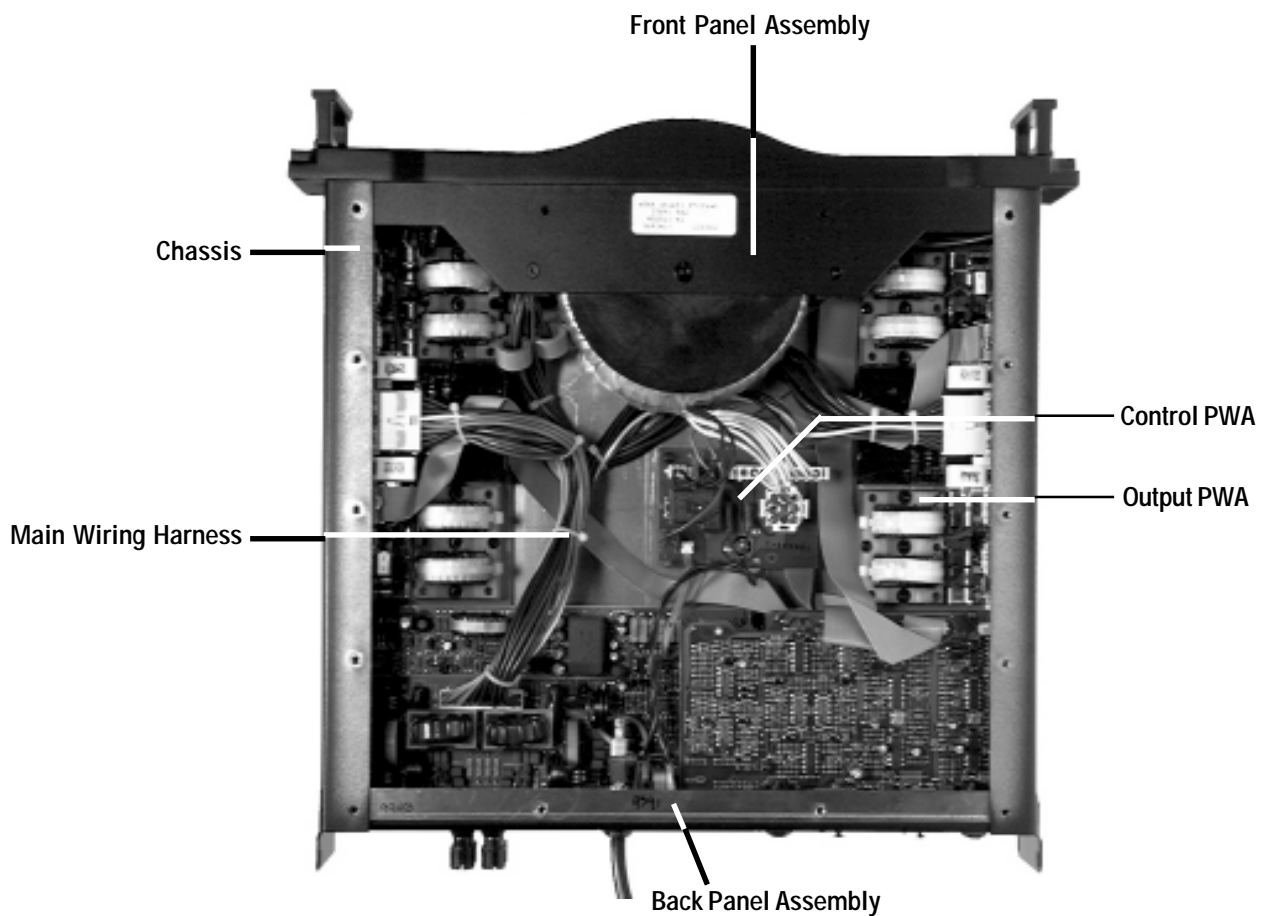

Figure 7.1 View of Main Chassis from Bottom

## 7.2 Main Chassis Assembly

Refer to figure 7.1 for Location of Major Parts

Description	Part # (CPN)	Qty.	Notes
Chassis	102226-X	1	
Front Panel Assembly	-	1	See 6.4
Back Panel Assembly	-	1	See 6.5
Bottom Cover	102076-X	1	
Control PWA	-	1	See Sect. 7
Output PWA	-	2	See Sect. 7
Screw, 8-32 X .812 T20	A12148-70813	12	
Rear Support	100848-X	2	
Insulator, Output PWA	100536-X	2	
#6 Internal Star Washer, Black	A10094-3	7	
#8 Belleville Washer	A10098-3	13	
8-32 Hex Nut	A10102-6	1	
Screw, 6-32X.375 Pan HD T15	A12148-70606	7	
5.5" Cable Tie	C 8812-7	3	
35A 400V Bridge, Wire Lead	C10246-4	1	At Control PCA
Screw, 8-32X.5 Flt Hd T15	100331-70808	18	Cover
Screw, 8-32X.312 Flt Hd T15	100331-70805	5	Top Rear
Screw, 8-32X.5 Flt Hd T15	101087-70808	8	Front Panel to Chassis
Lockwasher, CSK Ext Tooth #8	101357-1	31	
Wire, Pwr Switch Violet	A11569-E160F	2	
Wire Pwr Switch Orange	A12122-C140D	2	
Main Wiring Harness	101838-1	1	
	101528-1	1	Early non-CE Models Only

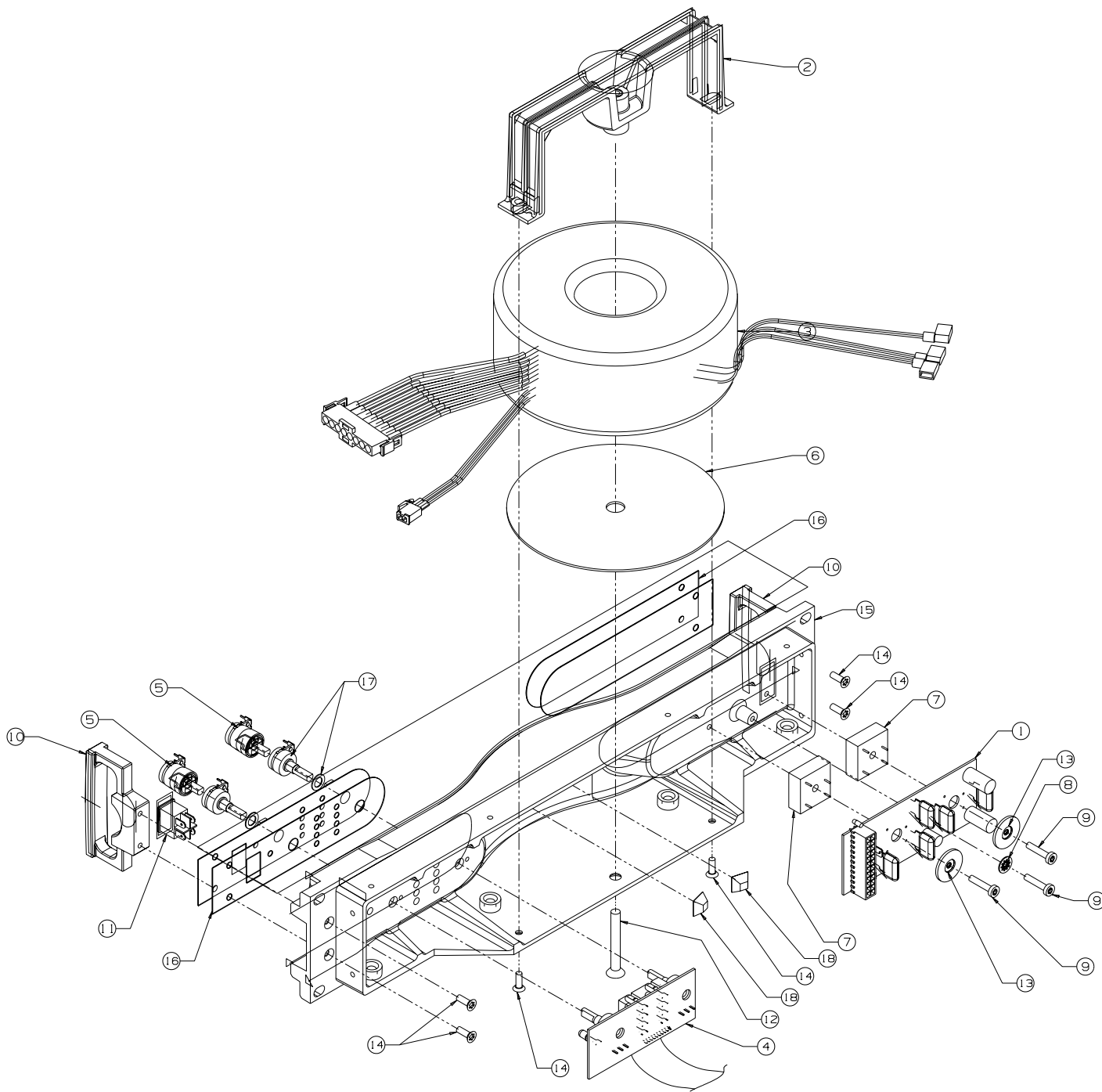

Figure 7.2 Front Panel Assembly Exploded View



### 7.3 Front Panel Assembly

Refer to figure 7.2 for Exploded View

Item #	Description	Part # (CPN)	Qty.	Notes
1	Bridge Rect. PWA	100444-X	1	See 6.9
2	Bracket, Transformer Mounting	100124	1	
3	Power Transformer, K2	102236-1	1	w/connectors
	Power Transformer, K1	H43525-7	1	w/connectors
4	Display PCA	102552-X	1	See 6.10
5	Knob, K2	D 8959-5	2	
6	Rubber Washer, Toroid	A10659-6	1	
-	Rubber Dampening Pad	102243-1	1	K1
7	Bridge, 35A 400V Wire Lead	C10246-4	2	Qty 1 for K1
8	Lock Washer, #8 Internal Star	A10094-6	1	
9	Screw, 8-32 x .812 PNHD T20	A12148-70813	3	
10	Handle	F12722-9	2	
11	Switch, Rocker DPDT 10A	100222-1	1	
12	Screw, 1/4-20 x 2.0 FLTHD T27	A12149-72532	1	
13	Belleville Washer, #8	A10098-3	2	
14	Screw, 8-32 x .5 UC FLTHD T15	100331-70808	6	
15	Front Panel	F12717-9	1	
16	Overlay, Set, K2 Front Panel	102181-X	1	
16	Overlay, Set, K1 Front Panel	102183-X	1	
17	5K Ohm Vol Pot Hardware	C10245-6	2	Pot w/Hrdwr
18	Feet, Selfstick Black	C 3342-0	2	

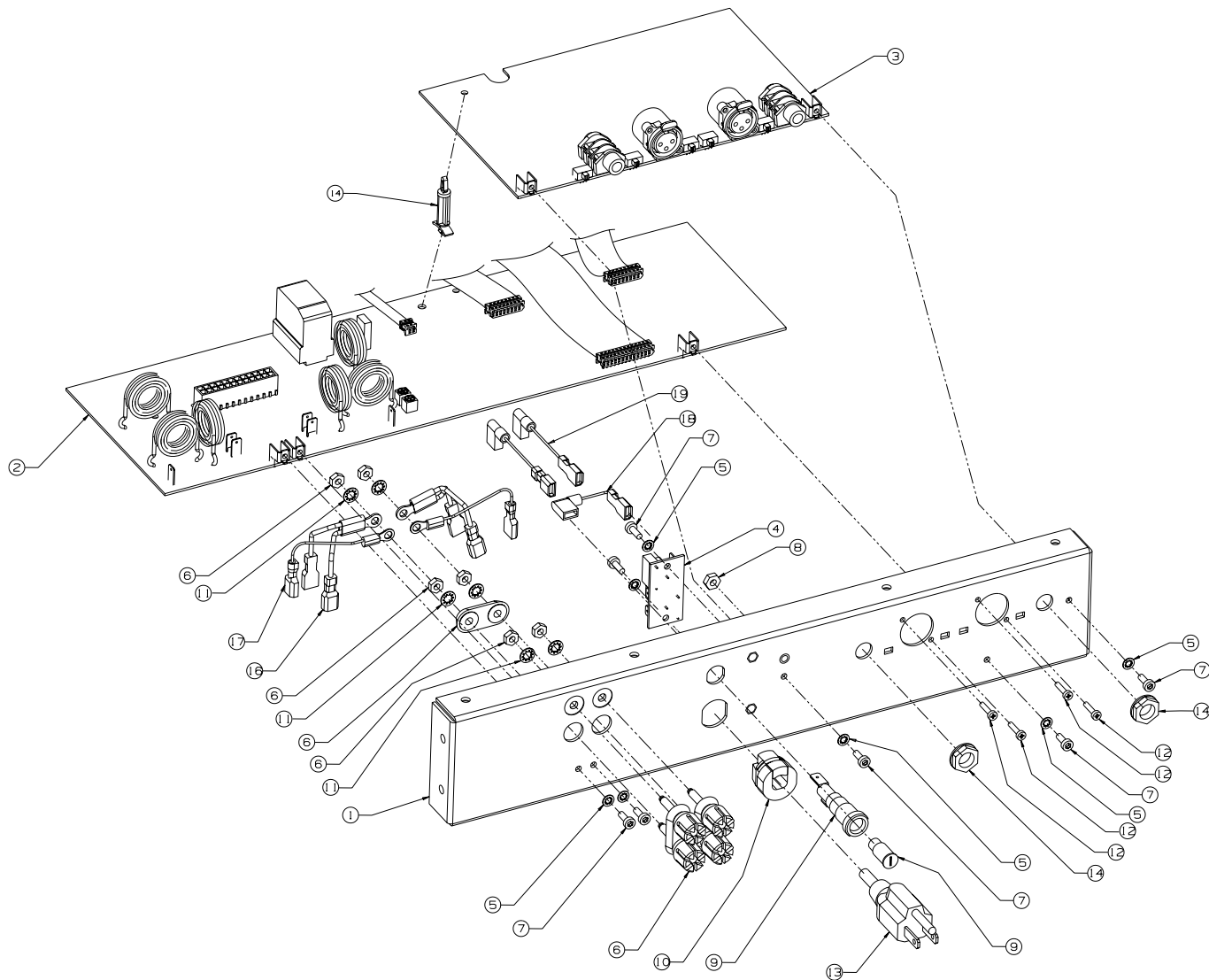

Figure 7.3 Back Panel Assembly Exploded View

## 7.4 Back Panel Assembly

Refer to figure 7.3 for Exploded View

Item #	Description	Part # (CPN)	Qty.	Notes
1	Back Panel, K2	101085-X	1	
1	Back Panel, K1	102013-X	1	
2	Main PCA	100497-X	1	Complete
3	Input PCA, K1	101809-X	1	Complete
3	Input PCA, K2	100524-X	1	Complete
4	Line Filter PWA	101014-X	1	*
5	Lockwasher, #6 Int. Star	A10094-3	7	
6	Terminal, Dual Binding Post	C10184-7	2	w/hardware
7	Screw, 6-32 X .375 PNHD T15	A12148-70606	7	
8	8-32 Hex Nut	A10102-6	1	
9	Fuseholder, 3AG-Scrdvr-Slot	100850-1	1	
9X	Fuse	See Chapter 4	1	
10	Strain Relief	A10214-10	1	
11	Lockwasher, #10 Int. Star	A10094-8	6	
12	Screw, #4 X .5 PNHD PH	A10111-70408	4	
13	Power Cord:			
	A1/E3/E8/E17/Dom. (Nema 5-15)	101011-2	1	
	E13 Models (Schuko plug)	A10793-0508T	1	
	E14 Models (BS 1363 plug)	A10793-0608T	1	
	E24 Models (Old BS plug)	A10793-0708T	1	
	E34 Models (Australia)	A10793-0908T	1	
14	Nut, Phone Jk 1/4" PC Mount	C10226-1	2	
15	PC Board Support, 1"	100939-1	1	
16	Output Wires	100537-1	2	w/connectors
17	Wire (feedback)	A11382-F040L	2	w/connectors
18	Wire (Line Filter Power)	A11384-C020M	1	w/connectors
19	Blk Wire (Control Power) P8	A11384-C095M	1	w/connectors *
	Wht Wire (Control Power) P9	A11565-A095M	1	w/connectors *

\* Denotes part used with early, non-CE models only

# 8 Module and Schematic Information

## 8.1 General Information

Since the introduction of the *K Series* amplifiers there have been several updates and revisions. Many of these changes called for new modules. The following pages list all modules used as of the printing of this manual.

When replacing an Output PWA, it is recommended that you order a complete, pre-assembled Output Assembly, which includes the PWA, heatsink, matched output inductors and other parts.

The Crown Parts Department stocks the most current PWAs and Output Assemblies for each *K Series* model, which will retrofit into all older units.

Parts lists and schematics for Main, Output, and Input PWAs are included beginning with current production PWAs as of Revision A of this manual. Call the Crown Technical Support Group if you require a parts list or schematic for a module not included in this manual.

The schematics referenced and provided are representative only. There may be slight variations between amplifier to amplifier. These schematics are intended to be used for troubleshooting purposes only.

Note on circuit board designations: Crown circuit boards are referenced with a PWA and/or PWB part number. PWA stands for Printed Wire Assembly. This is the completed circuit board with all components assembled. PWB stands for Printed Wire Board. This is the circuit board only, without components.

## 8.2 PWAs

### 8.2.1 Main PWA:

100497-1

Main PWA built on 100496-1 PWB.

100497-2

Main PWA built on 100496-2 PWB. Replaced 100496-1.

100497-3

Main PWA built on 100496-3 PWB. Replaced 100496-2.

100497-4

Main PWA built on 100496-4 PWB. Replaced 100496-3.

100497-5

Main PWA built on 100496-5 PWB. Replaced 100496-4.

### 8.2.2 Input PWA:

102524-1

Input PWA built on 100523-1 PWB.

102524-2

Input PWA built on 100523-2 PWB. Replaced 100523-1.

102524-3

Input PWA built on 100523-5 PWB. Replaced 100523-2.

#### K1

101809-1

Input PWA built on 100523-5 PWB. Replaced 100523-3 with K1.

101809-2

Input PWA built on 100523-5 PWB. Replaced 101809-1.

101809-3

Input PWA built on 100523-7 PWB. Replaced 101809-2.

101809-4

Input PWA built on 100523-7 PWB. Replaced 101809-3.

#### K2

102524-4

Input PWA built on 100523-5 PWB. Replaced 100523-3 with K2.

102524-5

Input PWA built on 100523-7 PWB. Replaced 100523-4.

102524-6

Input PWA built on 100523-7 PWB. Replaced 100523-5.

### 8.2.3 Output PWA:

Note: When replacing an Output PWA, Crown recommends that you order a complete, pre-assembled Output Assembly, which includes the PWA, heatsink, matched output inductors and other parts. CPNs for Output Assemblies are given after Output PWA listings below for K1 and K2..

#### K1

101795-1

Output PWA built on 100437-2 PWB.

102176-1

Output PWA built on 100437-2 PWB. Replaced 101795-1.

102176-2

Output PWA built on 100437-3 PWB. Replaced 102176-1.

102175-2

Complete Output Assembly. Replaces all earlier Output Assemblies.

**K2**100438-1

Output PWA built on 100437-1 PWB.

100438-2

Output PWA built on 100437-2 PWB. Replaced 100438-1.

100438-3

Output PWA built on 100437-3 PWB. Replaced 100438-2.

101554-2

Complete Output Assembly. Replaces all earlier Output Assemblies.

**8.2.4 Control PWA:**Q43425-0

Control PWA built on 100109-1 PWB.

100469-1

Control PWA built on 100109-2 PWB. Replaced Q43425-0.

101850-1

Control PWA built on 101849-1 PWB. Used in CE-approved models.

**8.2.5 Bridge Rectifier PWA:**100444-1

Bridge Rectifier PWA built on 100443-1 PWB.

101865-1

Bridge Rectifier PWA built on 100443-2 PWB. Used starting with CE approved models. Replaced 100444-1.

**8.2.6 Display PWA:**Q43449-0

Display PWA built on D9242-5 PWB.

102552-1

Display PWA built on 102551-1 PWB. Replaced Q43449-0.

102552-2

Display PWA built on 102551-1 PWB. Added foam LED insulator. Replaced 102552-1.

**8.2.7 Line Filter PWA:**101014-1

Line Filter PWA built on 101013-1 PWB.

101014-2

Line Filter PWA built on 101013-2 PWB. Replaced 101014-1.

**8.3 Schematic Diagrams****8.3.1 Main PWA**For PWA 100497-5 refer to schematic 100495 G.**8.3.2 Input PWA****K1**For PWA 101809-4 refer to schematic 101946 F.**K2**For PWA 100524-6 refer to schematic 100522 M.**8.3.3 Output PWA****K1**For PWA 102176-2 refer to schematic 102195 C.**K2**For PWA 100438-3 refer to schematic 100436 D.**8.3.4 Control PWA**For PWA 100469-1 refer to schematic 100468 A.For PWA 101850-1 refer to schematic 101848 B.**8.3.5 Bridge Rectifier PWA**For PWA 101865-1 refer to schematic 100442 C.**8.3.6 Display PWA**For PWA 102552-1 refer to schematic 102550 A.**8.3.7 Line Filter PWA**For PWA 101014-2 refer to schematic 101012 B.

This page left intentionally blank

---

## 9 Module Parts

---

### 9.1 General Information

This chapter includes electrical parts lists for this product. All serviceable parts and assemblies will have a Crown Part Number (CPN) listed in this chapter. The parts listed are current as of the date printed. Crown reserves the right to modify and improve its products for the benefit of its customers.

**100438-3**

**100469-1**

**100497-5**

**100524-6**

**101014-2**

**101554-2**

**101809-4**

**101850-1**

**101865-1**

**102175-2**

**102176-2**

**102552-1**

E. C.	ZONE	REV.	DESCRIPTION	DATE	BY	APPROVALS				
						CHK	ME	EE	PE	
S00479		E	REVISED AND REDRAWN. ELIMINATED REVISION CONTROL SHEETS AND UPDATED ALL SHEET REV'S TO "E". NOTE 2 WAS 100437-2, NOTE 3 WAS 100438-2. 101031-1 WAS C 7817-1, C 8158-5 DESC. WAS 1SS143.	11-03-97	KLW	JAW				JY
S00479		F	ADDED NOTES 10 AND 11.	02-13-98	JAW	KW				JY

NOTES:

1. SCHEMATIC DRAWING NUMBER 100436.
2. PRINTED WIRING BOARD PART NUMBER 100437-3.
3. PRINTED WIRING ASSEMBLY PART NUMBER 100438-3.



CAUTION

STATIC CAN DAMAGE COMPONENTS!

DO NOT HANDLE

UNLESS WRIST STRAP IS WORN

THESE DRAWINGS AND SPECIFICATIONS ARE THE PROPERTY OF CROWN INTERNATIONAL, INC. AND SHALL NOT BE REPRODUCED, COPIED, OR USED AS THE BASIS FOR THE MANUFACTURE OR SALE OF APPARATUS OR DEVICES WITHOUT PERMISSION.

CROWN INTERNATIONAL INC.									
PRINTS TO		1718 WEST MISHAWAKA ROAD ELKHART, INDIANA 46517				PHONE (219) 294-8000			
K		PWA, OUTPUT K2						TOL. UNLESS SPECIFIED X.XX = ± 0.020 X.XXX = ± 0.010 DRILLS = ± 0.003	
		DRAWN	KLW	11-03-97	APPROVED BY:		DO NOT SCALE PRINT		
		CHECKED			ME		SUPERSEDES		
		SCALE	NONE		EE		E. C. N.		
		PROJ	MD350S0		PE	JY	11-3-97	C. P. N. SHEET 1 OF 6	REV
		NEXT ASSEMBLY				100438		(F)	



PARTS LIST			
REF DES	C. P. N.	DESCRIPTION	MAP LOC.
C01	C10208-4	100.UF 25V 20% RAD ELECT T/R	A 2
C02	C10208-4	100.UF 25V 20% RAD ELECT T/R	A 2
C03	C10208-4	100.UF 25V 20% RAD ELECT T/R	A 2
C04	C10208-4	100.UF 25V 20% RAD ELECT T/R	A 2
C05	C 6804-6	.1UF 50V AXIAL CER T/R 104	B 2
C06	C 6804-6	.1UF 50V AXIAL CER T/R 104	B 2
C07	C 6804-6	.1UF 50V AXIAL CER T/R 104	B 1
C08	C 6804-6	.1UF 50V AXIAL CER T/R 104	B 1
C09	C10208-4	100.UF 25V 20% RAD ELECT T/R	B 2
C10	C10238-1	330.PF 500V MIN 10% CER DISK	A 1
C11	C10238-1	330.PF 500V MIN 10% CER DISK	C 1
C12	A10434-473JD	.047UF 250VDC 5% MET POLY T/A	E 2
C13	A10434-104JD	.1UF 250V 5% MTL POLY FILM T/A	F 3
C14	A10434-103JD	.01UF 250V 5%MTL POLY FILM T/A	A 1
C15	A10434-103JD	.01UF 250V 5%MTL POLY FILM T/A	A 1
C16	A10434-103JD	.01UF 250V 5%MTL POLY FILM T/A	A 1
C17	C 8963-8	0.47 UF 250V 5% MET POLY	A 2
C18	A10434-103JD	.01UF 250V 5%MTL POLY FILM T/A	C 1
C19	A10434-103JD	.01UF 250V 5%MTL POLY FILM T/A	C 1
C20	A10434-103JD	.01UF 250V 5%MTL POLY FILM T/A	C 1
C21	C 8963-8	0.47 UF 250V 5% MET POLY	C 2
C22	D 8917-3	8200UF 110VDC ELECTROLYTIC	D 2
C23		--- NOT USED ---	B 3
C24		--- NOT USED ---	B 3
C55	C 6804-6	.1UF 50V AXIAL CER T/R 104	H 2
C57	C 6804-6	.1UF 50V AXIAL CER T/R 104	G 1
C58	C 6804-6	.1UF 50V AXIAL CER T/R 104	H 1
C59	C10208-4	100.UF 25V 20% RAD ELECT T/R	G 2
C60	C10238-1	330.PF 500V MIN 10% CER DISK	I 1
C61	C10238-1	330.PF 500V MIN 10% CER DISK	F 1
C62	A10434-473JD	.047UF 250VDC 5% MET POLY T/A	E 2
C64	A10434-103JD	.01UF 250V 5%MTL POLY FILM T/A	H 1
C65	A10434-103JD	.01UF 250V 5%MTL POLY FILM T/A	H 1
C66	A10434-103JD	.01UF 250V 5%MTL POLY FILM T/A	H 1
C67	C 8963-8	0.47 UF 250V 5% MET POLY	H 2
C68	A10434-103JD	.01UF 250V 5%MTL POLY FILM T/A	G 1
C69	A10434-103JD	.01UF 250V 5%MTL POLY FILM T/A	G 1
C70	A10434-103JD	.01UF 250V 5%MTL POLY FILM T/A	G 1
C71	C 8963-8	0.47 UF 250V 5% MET POLY	G 2
C72	D 8917-3	8200UF 110VDC ELECTROLYTIC	E 2
C73		--- NOT USED ---	G 2
C74		--- NOT USED ---	G 3
D01	C10463-5	DIODE, ULTRAFAST MUR120 T/R	A 2
D02	C10463-5	DIODE, ULTRAFAST MUR120 T/R	A 2
D03	D 9053-6	DIODE, 300V ULTRAFAST TO-220	B 1
D04	D 9053-6	DIODE, 300V ULTRAFAST TO-220	B 1
D05	C 8158-5	DIODE, SWITCHING 1SS244T T/R	F 2

### CROWN INTERNATIONAL INC.

1718 WEST MISHAWAKA ROAD ELKHART, INDIANA 46517 PHONE (219) 294-8000

THESE DRAWINGS AND SPECIFICATIONS ARE THE PROPERTY OF CROWN INTERNATIONAL, INC. AND SHALL NOT BE REPRODUCED, COPIED, OR USED AS THE BASIS FOR THE MANUFACTURE OR SALE OF APPARATUS OR DEVICES WITHOUT PERMISSION.

DRAWN K LW 11-03-97

DWG. NO.

SHEET 3 OF 6

REV

PROJ. MD35050

100438

F



PARTS LIST			
REF DES	C.P.N.	DESCRIPTION	MAP LOC.
D53	D 9053-6	DIODE, 300V ULTRAFAST TO-220	G 1
D54	D 9053-6	DIODE, 300V ULTRAFAST TO-220	H 1
L51	C10214-2	CHOKER, 100UH 20%	H 2
NTC01	C10215-9	NTC, THERMISTOR 20KOHM @25DEGC	E 1
P3	C10274-6	16POS MINI MATE-N-LOK VERT HDR	E 3
P01	C10273-8	16 PIN HDR PICOFLEX TIN	B 2
Q01	C10207-6	MOSFET, 250V 16A MTP16N25E	A 1
Q02	C10207-6	MOSFET, 250V 16A MTP16N25E	A 1
Q03	C10207-6	MOSFET, 250V 16A MTP16N25E	C 1
Q04	C10207-6	MOSFET, 250V 16A MTP16N25E	C 1
Q51	C10207-6	MOSFET, 250V 16A MTP16N25E	F 1
Q52	C10207-6	MOSFET, 250V 16A MTP16N25E	G 1
Q53	C10207-6	MOSFET, 250V 16A MTP16N25E	H 1
Q54	C10207-6	MOSFET, 250V 16A MTP16N25E	I 1
R01	C10448-6	10.OHM .25W 5% FU/FP T/R	A 1
R02	C10448-6	10.OHM .25W 5% FU/FP T/R	A 1
R03	C10448-6	10.OHM .25W 5% FU/FP T/R	B 1
R04	C10448-6	10.OHM .25W 5% FU/FP T/R	C 1
R05	A10266-1511	150.OHM .25W 5 CF T/R	B 3
R06	A10266-1511	150.OHM .25W 5 CF T/R	B 3
R07	A10266-1021	1.0 KOHM .25W 5% CF T/R	B 2
R08	C 9588-2	15.OHM 3W 5% MF FP	A 2
R09	C 9588-2	15.OHM 3W 5% MF FP	C 2
R10	100115-1	91, 2W, 5%, MF, 1W BODY	G 3
R11	100115-1	91, 2W, 5%, MF, 1W BODY	G 3
R12	100115-1	91, 2W, 5%, MF, 1W BODY	G 3
R13	C10450-2	.04 OHM 5W 3% WW VERT MNT	D 3
R14	C10450-2	.04 OHM 5W 3% WW VERT MNT	D 2
R15	C10449-4	2.7OHM .25W 5% MF T/R	A 2
R16	C10449-4	2.7OHM .25W 5% MF T/R	A 2
R17	C10449-4	2.7OHM .25W 5% MF T/R	A 2
R18	C10449-4	2.7OHM .25W 5% MF T/R	A 2
R19	C10449-4	2.7OHM .25W 5% MF T/R	C 2
R20	C10449-4	2.7OHM .25W 5% MF T/R	C 2
R21	C10449-4	2.7OHM .25W 5% MF T/R	C 2
R22	C10449-4	2.7OHM .25W 5% MF T/R	C 2
R23	A10266-5R61	5.6 OHM .25W 5% CF T/R	D 3
R24	A10266-5R61	5.6 OHM .25W 5% CF T/R	D 3
R25	C10447-8	100.KOHM HORZ ADJ TRIMMER T/R	C 3
R51	C10448-6	10.OHM .25W 5% FU/FP T/R	G 1
R52	C10448-6	10.OHM .25W 5% FU/FP T/R	G 1
R53	C10448-6	10.OHM .25W 5% FU/FP T/R	H 1
R54	C10448-6	10.OHM .25W 5% FU/FP T/R	H 1
R55	A10266-1511	150.OHM .25W 5 CF T/R	G 2
R56	A10266-1511	150.OHM .25W 5 CF T/R	G 3

<b>CROWN INTERNATIONAL INC.</b>			
1718 WEST MISHAWAKA ROAD		ELKHART, INDIANA 46517	PHONE (219) 294-8000
THESE DRAWINGS AND SPECIFICATIONS ARE THE PROPERTY OF CROWN INTERNATIONAL, INC. AND SHALL NOT BE REPRODUCED, COPIED, OR USED AS THE BASIS FOR THE MANUFACTURE OR SALE OF APPARATUS OR DEVICES WITHOUT PERMISSION.	DRAWN	KLW 11-03-97	DWG. NO. 100438
	PROJ.	MD35050	SHEET 4 OF 6 REV (F)

PARTS LIST			
REF DES	C.P.N.	DESCRIPTION	MAP LOC.
R57	A10266-1021	1.0 KOHM .25W 5% CF T/R	H 2
R58	C 9588-2	15. OHM 3W 5% MF FP	I 2
R59	C 9588-2	15. OHM 3W 5% MF FP	F 2
R60	100115-1	91, 2W, 5%, MF, 1W BODY	H 3
R61	100115-1	91, 2W, 5%, MF, 1W BODY	H 3
R62	100115-1	91, 2W, 5%, MF, 1W BODY	H 3
R63	C10450-2	.04 OHM 5W 3% WW VERT MNT	F 3
R64	C10450-2	.04 OHM 5W 3% WW VERT MNT	F 2
R65	C10449-4	2.7OHM .25W 5% MF T/R	I 2
R66	C10449-4	2.7OHM .25W 5% MF T/R	H 2
R67	C10449-4	2.7OHM .25W 5% MF T/R	H 2
R68	C10449-4	2.7OHM .25W 5% MF T/R	H 2
R69	C10449-4	2.7OHM .25W 5% MF T/R	G 2
R70	C10449-4	2.7OHM .25W 5% MF T/R	G 2
R71	C10449-4	2.7OHM .25W 5% MF T/R	F 2
R72	C10449-4	2.7OHM .25W 5% MF T/R	F 2
R73	A10266-5R61	5.6 OHM .25W 5% CF T/R	E 3
R74	A10266-5R61	5.6 OHM .25W 5% CF T/R	E 3
R75	A10266-1021	1.0 KOHM .25W 5% CF T/R	H 2
T01	H43506-7	XFMR, GATE DRIVE SUPPLY	A 3
TP1	C 9896-9	TEST POINT PCB .1"CTR LOOP T/R	B 2
TP51	C 9896-9	TEST POINT PCB .1"CTR LOOP T/R	G 2
U01	C 8075-1	LM78L05ACZ 5VOLT REGULATOR T/A	B 2
U02	C10287-8	OPTOCOUPLER HI SPD HCPL-2611	B 2
U03	C 8613-9	MC34151P HISPDP DUAL MOSFET DVR	B 1
U51	C 8075-1	LM78L05ACZ 5VOLT REGULATOR T/A	H 2
U52	C 8614-7	TLP2601 HI SPEED OPTO	H 2
U53	C 8613-9	MC34151P HISPDP DUAL MOSFET DVR	H 1
VN	101031-1	.250 FASTON, AUTO INSERTABLE	G 2
VN2	101031-1	.250 FASTON, AUTO INSERTABLE	F 2
VP	101031-1	.250 FASTON, AUTO INSERTABLE	B 2
VP2	101031-1	.250 FASTON, AUTO INSERTABLE	C 2
	101016-1	LBL, BARCODE	I 3

THESE DRAWINGS AND SPECIFICATIONS ARE THE PROPERTY OF CROWN INTERNATIONAL, INC. AND SHALL NOT BE REPRODUCED, COPIED, OR USED AS THE BASIS FOR THE MANUFACTURE OR SALE OF APPARATUS OR DEVICES WITHOUT PERMISSION.	<b>CROWN INTERNATIONAL INC.</b>				
	1718 WEST MISHAWAKA ROAD ELKHART, INDIANA 46517 PHONE (219) 294-8000				
	DRAWN	KLW	11-03-97	DWG. NO.	SHEET 5 OF 6
PROJ.	MD35050		100438		Ⓢ

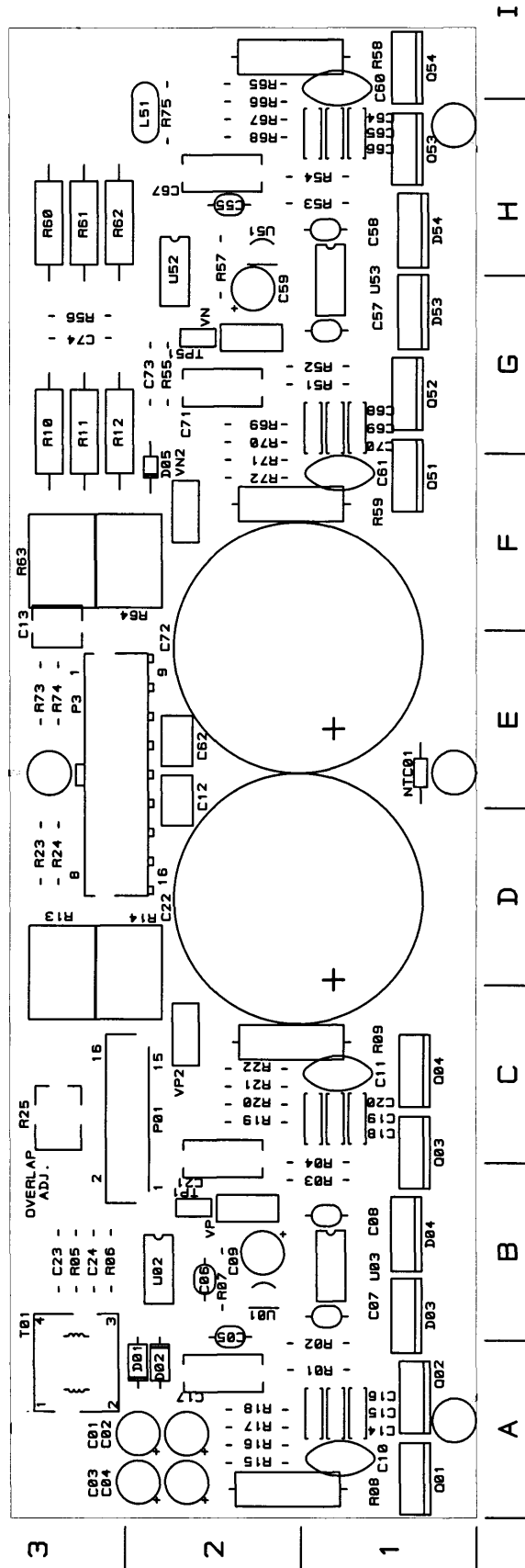

100438-3 Component Map (Component Side of Module)

E.C.	ZONE	REV.	DESCRIPTION	DATE	BY	APPROVALS			
						CHK	ME	EE	PE
		A	INITIAL RELEASE. REPLACES M46616-5	01-21-97	KLW				JW
		B	ADDED NOTE 4.	01-30-97	KLW				JW
97E038C		C	DELETED A10098-6 AND A12148-70606. ADDED 101161-1.	02-20-97	KLW				EB
S00479		D	INITIAL RELEASE OF 101554-2. ADDED A10098-6. 102777-2 WAS D 8952-0. 100438-3 WAS 100438-2. A12148-70606 WAS 101161-1. NOTE 4 WAS 101554-1	11-03-97	KLW	JAW			JW

NOTES:

1. APPLY RTV RUBBER (S 5700-0) TO NTC01 ON OUTPUT BOARD TO MAKE A THERMAL CONNECTION BETWEEN NTC01 AND HEATSINK (100527-1).
2. ON THE 20UH INDUCTORS, THE OUTSIDE COILS LEAD SHOULD BE CONNECTED TO THE VP2 OR VN2 CONNECTOR. THE INSIDE COILS LEAD SHOULD BE CONNECTED TO THE VP OR VN.
3. APPLY RTV RUBBER (S 5700-0) TO C12 AND C72 ON OUTPUT ASSEMBLY TO SECURE C12 AND C72 TO THE HEATSINK (100527-1).
4. THE ASSEMBLY PART NUMBER (101554-2) SHALL BE MARKED ON THE ASSEMBLY AND SHALL BE PERMANENT.

PARTS LIST			
C.P.N.	DESCRIPTION	QTY	REFERENCE DESIGNATION
A10098-6	#6 BELLEVILLE WASHER SS	9	
A12148-70606	6-32 X .375 PAN HD T15 BZ	11	
D 8958-7	INS. CERAMIC .90 X .75 X.040	3	
H43507-5	INDUCTOR, 20UH 40A MATCHED P	1	
S 2162-6	TYPE 340 HEATSINK COMPOUND	0	
S 5700-0	732 RTV RUBBER 10.3 OZ CLEAR	0	
100438-3	PWA, OUTPUT K2	1	
100527-1	HEATSINK, D350 MAIN	1	
102777-2	CLIP, K SERIES FET	2	

THESE DRAWINGS AND SPECIFICATIONS ARE THE PROPERTY OF CROWN INTERNATIONAL, INC. AND SHALL NOT BE REPRODUCED, COPIED, OR USED AS THE BASIS FOR THE MANUFACTURE OR SALE OF APPARATUS OR DEVICES WITHOUT PERMISSION.

PRINTS TO		<b>CROWN INTERNATIONAL INC.</b>				1718 WEST MISHAWAKA ROAD ELKHART, INDIANA 46517		PHONE (219) 294-8000	
		K		OTPT, K2 PWA W/HS				TOL. UNLESS SPECIFIED X.XX = ± 0.020 X.XXX = ± 0.010 DRILLS = ± 0.003	
		DRAWN	KLW	01-21-97	APPROVED BY:		DO NOT SCALE PRINT		
		CHECKED			ME		SUPERSEDES M46616-5		
		SCALE	NONE		EE		E.C.N.		
		PROJ	MD350S0		PE	JW	01-22-97	C.P.N.	REV
		NEXT ASSEMBLY				101554		(D)	

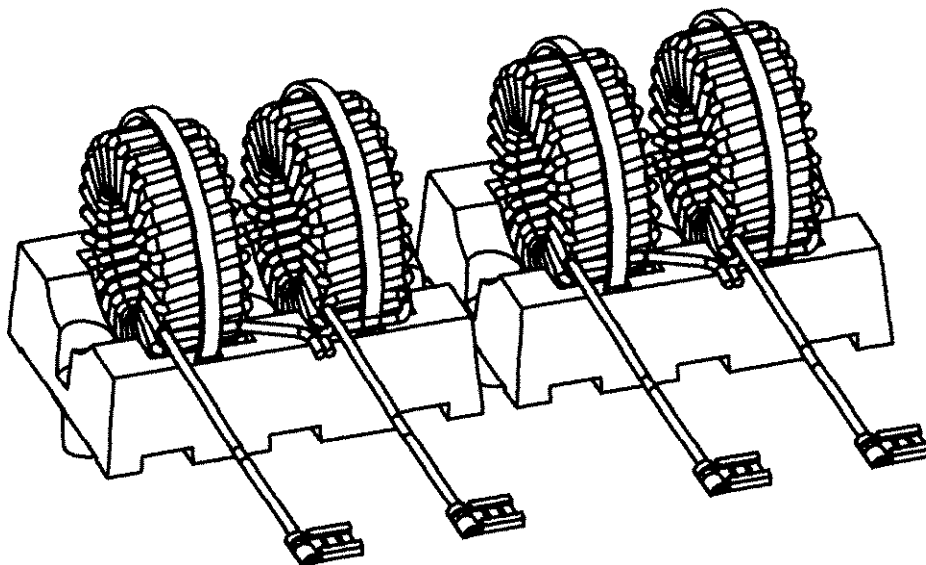

*View of Inductor Pair, CPN H43507-5, for Output Assembly CPN 101554*

NOTES:

1. SCHEMATIC DRAWING NUMBER 100468.
2. PRINTED WIRING BOARD PART NUMBER 100109-2.
3. PRINTED WIRING ASSEMBLY PART NUMBER 100469-1.
4. THE PRINTED WIRING ASSEMBLY SHALL MEET THE IPC-A-610 CLASS 2 STANDARDS.
5. ALL LEADS SHALL BE TRIMMED TO 0.093" OR LESS.
6. POSITION COMPONENTS AS SHOWN ON COMPONENT MAP.
8. THE PRINTED WIRING ASSEMBLY PART NUMBER AND DRAWING REVISION FOR THIS ASSEMBLY SHALL BE MARKED ON THE PRINTED WIRING BOARD AND SHALL BE PERMANENT.
9. INSTALL 5 OHM PTC(C 8960-4) INTO TO-220 TRANSISTOR HOLDER (C 8982-8) PRIOR TO INSTALLING PTC.
10. SECURE 5 OHM PTC(C 8960-4) AND TO-220 TRANSISTOR HOLDER TO PRINTED WIRING BOARD USING RTV RUBBER (S 5700-0).

	<p><b>CAUTION</b></p> <hr/> <p>STATIC CAN DAMAGE COMPONENTS!</p> <p><b>DO NOT HANDLE</b></p> <p>UNLESS WRIST STRAP IS WORN</p>
---	--

<b>CROWN INTERNATIONAL INC.</b>						
1718 WEST MISHAWAKA ROAD ELKHART, INDIANA 46517 PHONE (219) 294-8000						
THESE DRAWINGS AND SPECIFICATIONS ARE THE PROPERTY OF CROWN INTERNATIONAL, INC. AND SHALL NOT BE REPRODUCED, COPIED, OR USED AS THE BASIS FOR THE MANUFACTURE OR SALE OF APPARATUS OR DEVICES WITHOUT PERMISSION.	DRAWN	KLW	10-18-96	DWG. NO.	SHEET 3	REV
	PROJ.	D350	100469	CONT. ON SHEET 4		



PARTS LIST			
REF DES	C. P. N.	DESCRIPTION	MAP LOC.
D1		--- INSTALLED ON NEXT ASSEMBLY ---	C 1
D2	C 2851-1	RECTIFIER, 1N4004 SILICON T/R	A 2
K1	C10522-8	RELAY, 30A 110V PC MNT SEALED	A 2
P4	C10300-9	4 POS PICO FLEX HDR TIN	A 1
P5	C10313-2	8 POS MATE-N-LOK VERT HDR	C 3
P6	C10297-7	2 POS MINI MATE-N-LOK HDR	A 3
P7	100365-1	HDR, MATE-N-LOK, 9PIN, VERT H	C 2
P8	C 7817-7	FASTON, TAB .250 PC MNT	B 2
P9	C 7817-7	FASTON, TAB .250 PC MNT	C 2
P10	C 7817-7	FASTON, TAB .250 PC MNT	B 3
P11	C 7817-7	FASTON, TAB .250 PC MNT	B 3
P12	C 7817-7	FASTON, TAB .250 PC MNT	A 1
P13	C 7817-7	FASTON, TAB .250 PC MNT	A 1
R1	C 8960-4	5 OHM PTC THERMISTOR	A 3
R1X	C 8982-8	TO-220 XSISTOR HOLDER, PLASTIC	A 3

<small>THESE DRAWINGS AND SPECIFICATIONS ARE THE PROPERTY OF CROWN INTERNATIONAL, INC. AND SHALL NOT BE REPRODUCED, COPIED, OR USED AS THE BASIS FOR THE MANUFACTURE OR SALE OF APPARATUS OR DEVICES WITHOUT PERMISSION.</small>	<b>CROWN INTERNATIONAL INC.</b>				
	1718 WEST MISHAWAKA ROAD		ELKHART, INDIANA 46517		PHONE (219) 294-8000
	DRAWN	KLW	10-10-96	DWG. NO.	REV
PROJ.	D350D	100469		SHEET 5 CONT. ON SHEET 6 (A)	



# COMPONENT MAP

(COMPONENT SIDE VIEW)

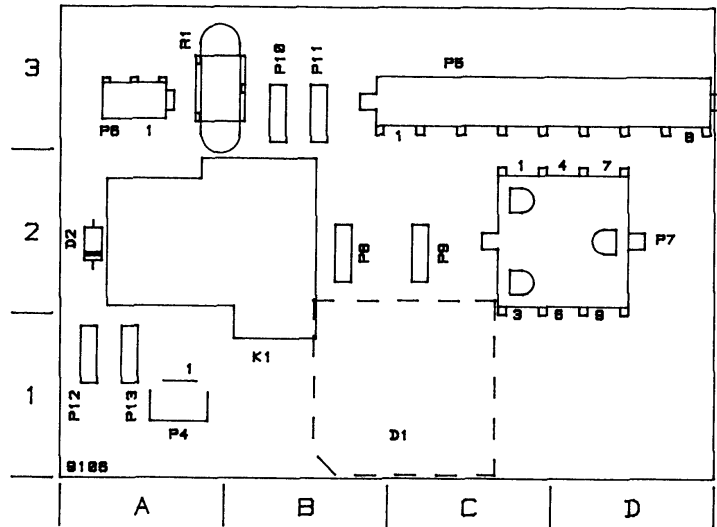

<b>CROWN INTERNATIONAL INC.</b>				
1718 WEST MISHAWAKA RD. ELKHART, INDIANA 46517 PHONE (219)294-8000				
THESE DRAWINGS AND SPECIFICATIONS ARE THE PROPERTY OF CROWN INTERNATIONAL, INC. AND SHALL NOT BE REPRODUCED, COPIED, OR USED AS THE BASIS FOR THE MANUFACTURE OR SALE OF APPARATUS OR DEVICES WITHOUT PERMISSION.	DRAWN	KLW	10-10-88	DWG. NO.
	PROJ.	D350D		SHEET
100469				REV <b>(A)</b>

E.C.	ZONE	REV.	DESCRIPTION	DATE	BY	APPROVALS				
						CHK	CE	EE	PE	
98E0582		A	PRODUCTION RELEASE (LEVEL I).	08-19-98	KLW	JAW				JY
98E0717		B	DELETE NOTE 7. RENUMBER NOTE 13 AS 7. REVISE NOTE 11. ASSIGNED VALUES FOR C128, C129, C228, C229. R145, R245 WERE 5.11K. 125102-1 WAS H43627-1. 126825-1 WAS S 5900-0. ADDED HW7.	01/18/99	JAW	Kw				JY

NOTES:

1. SCHEMATIC DRAWING NUMBER 100495.
2. PRINTED WIRING BOARD PART NUMBER 100496-5.



**CAUTION**

STATIC CAN DAMAGE COMPONENTS!  
DO NOT HANDLE  
UNLESS WRIST STRAP IS WORN

THESE DRAWINGS AND SPECIFICATIONS ARE THE PROPERTY OF CROWN INTERNATIONAL, INC. AND SHALL NOT BE REPRODUCED, COPIED, OR USED AS THE BASIS FOR THE MANUFACTURE OR SALE OF APPARATUS OR DEVICES WITHOUT PERMISSION.

<b>CROWN INTERNATIONAL INC.</b>										
PRINTS TO		1718 WEST MISHAWAKA ROAD ELKHART, INDIANA 48517				PHONE (219) 294-8000				
K		PWA, MAIN K2 & K1					TOL. UNLESS SPECIFIED X.XX = ± 0.020 X.XXX = ± 0.010 DRILLS = ± 0.003			
		DRAWN	KLW	08-19-98	APPROVED BY:		DO NOT SCALE PRINT			
		CHECKED	JAW	08-19-98	ME		SUPERSEDES			
		SCALE	NONE		EE		E. C. N.			
		PROJ	MD35050		PE	JY	08-19-98	C. P. N. SHEET 1 OF 22		REV
		NEXT ASSEMBLY					100497-5		(B)	

PARTS LIST			
REF DES	C.P.N.	DESCRIPTION	MAP LOC.
C1	C 8897-8	0.1 MF 100V 20% CERM	N 2
C2	C10503-8	.0047UF 50V 5% POLYESTER T/R *	N 2
C3	C10501-2	.022UF 50V 5% POLYESTER T/R *	O 3
C4	C 9161-8	0.01 MF 50V 10% RAD CERM	N 2
C5	C 8897-8	0.1 MF 100V 20% CERM	M 2
C6	C10208-4	100 MF 25V 20% VERT ELEC	O 2
C7	C10502-0	.0022UF 50V 5% POLYESTER T/R *	O 2
C8	C 8897-8	0.1 MF 100V 20% CERM	M 2
C9	C10208-4	100 MF 25V 20% VERT ELEC	M 2
C10	C 8897-8	0.1 MF 100V 20% CERM	M 1
C11	C10497-3	33UF 160V 20% VERT ELECT T/R	M 2
C12	C 9161-8	0.01 MF 50V 10% RAD CERM	M 2
C13	C 9161-8	0.01 MF 50V 10% RAD CERM	L 1
C14	C 8897-8	0.1 MF 100V 20% CERM	P 1
C15	C10517-8	470.UF 16V 20% LOW ESR RDL T/R	P 1
C16		OPEN	M 1
C17	C 6809-5	220 PF 100V 10% AX CERM	P 2
C18	C 6811-1	100 PF 200V 10% AX CERM	P 2
C19	C 8897-8	0.1 MF 100V 20% CERM	P 2
C20	C 6809-5	220 PF 100V 10% AX CERM	O 2
C21	C10502-0	.0022UF 50V 5% POLYESTER T/R *	P 2
C22	C10516-0	470.UF 10V 20% LOW ESR RDL T/R	L 2
C23	C10208-4	100 MF 25V 20% VERT ELEC	O 2
C24	C10208-4	100 MF 25V 20% VERT ELEC	O 3
C25	C 8897-8	0.1 MF 100V 20% CERM	L 2
C26	C10517-8	470.UF 16V 20% LOW ESR RDL T/R	L 2
C27	C10516-0	470.UF 10V 20% LOW ESR RDL T/R	L 1
C28	C10516-0	470.UF 10V 20% LOW ESR RDL T/R	L 2
C29	C10208-4	100 MF 25V 20% VERT ELEC	J 2
C30	C10208-4	100 MF 25V 20% VERT ELEC	J 2
C31	C10208-4	100 MF 25V 20% VERT ELEC	J 2
C32	C10208-4	100 MF 25V 20% VERT ELEC	J 1
C33	C 5362-6	2.2 MF 50V VERT	A 2
C34	C 5362-6	2.2 MF 50V VERT	B 1
C35	C 8897-8	0.1 MF 100V 20% CERM	F 2
C36	C 6804-6	0.1 MF 50V 10% CERM	C 1
C37	C 9746-6	62 PF 200V 5% AX CERM	D 1
C38	C 9746-6	62 PF 200V 5% AX CERM	D 1
C39	C 6807-9	0.001 MF 100V 10% AX CERM	I 2
C40	C 5362-6	2.2 MF 50V VERT	J 3
C41	C 6806-1	0.01 MF 100V AX CERM	G 1
C43	C 6807-9	0.001 MF 100V 10% AX CERM	I 4
C44	C 8897-8	0.1 MF 100V 20% CERM	I 3
C45	C10208-4	100 MF 25V 20% VERT ELEC	J 3
C46	C 8897-8	0.1 MF 100V 20% CERM	I 4
C47	C 8897-8	0.1 MF 100V 20% CERM	I 3
C48	C 8897-8	0.1 MF 100V 20% CERM	J 4

<b>CROWN INTERNATIONAL INC.</b>			
1718 WEST MISHAWAKA ROAD		ELKHART, INDIANA 46517	PHONE (219) 294-8000
DRAWN	KLW	8/19/98	DWG. NO.
PROJ.	MD350S0		100497-5
			SHEET 7 OF 22
			REV <b>B</b>

THESE DRAWINGS AND SPECIFICATIONS ARE THE PROPERTY OF CROWN INTERNATIONAL, INC. AND SHALL NOT BE REPRODUCED, COPIED, OR USED AS THE BASIS FOR THE MANUFACTURE OR SALE OF APPARATUS OR DEVICES WITHOUT PERMISSION.

PARTS LIST			
REF DES	C. P. N.	DESCRIPTION	MAP LOC.
C49	C 8897-8	0.1 MF 100V 20% CERM	J 4
C50	C 8897-8	0.1 MF 100V 20% CERM	G 2
C51	C 8897-8	0.1 MF 100V 20% CERM	G 2
C52	C 8897-8	0.1 MF 100V 20% CERM	D 6
C53	C10208-4	100 MF 25V 20% VERT ELEC	H 5
C54	C10208-4	100 MF 25V 20% VERT ELEC	H 5
C55	C 8897-8	0.1 MF 100V 20% CERM	I 5
C56	C 8897-8	0.1 MF 100V 20% CERM	H 5
C57	C 8897-8	0.1 MF 100V 20% CERM	B 2
C58	C 8897-8	0.1 MF 100V 20% CERM	B 2
C59	C10208-4	100 MF 25V 20% VERT ELEC	D 6
C60	C 8897-8	0.1 MF 100V 20% CERM	E 2
C61	C 7752-6	2.2 MF 50V NP 10% ELEC	I 3
C100	A11172-1	10PF 200V 5% NPO AXIAL CER T/R	F 4
C101	C 6808-7	470 PF 100V AX CERM	F 4
C102	C10521-0	39.PF 50V 5% NPO RDL MLC T/R	F 4
C103	C10518-6	3300.PF 50V 1% X7R RDL MLC T/R	F 5
C104	C10518-6	3300.PF 50V 1% X7R RDL MLC T/R	F 5
C105	C 9621-1	100 PF 200V 5% AX CERM	F 4
C106	C10519-4	220.PF 200V 1% NPO RDL MLC T/R	G 4
C107	C 6807-9	0.001 MF 100V 10% AX CERM	G 4
C108	C10499-9	.047UF 50V 5% POLYESTER T/R *	G 5
C109	A10434-103JD	0.01 MF 250V 5% POLY	G 5
C110	A11172-1	10PF 200V 5% NPO AXIAL CER T/R	E 4
C111	100114-1	330PF 200V 5% AXIAL CER T/R	G 6
C112	C 6809-5	220 PF 100V 10% AX CERM	G 6
C113	A11172-1	10PF 200V 5% NPO AXIAL CER T/R	F 5
C114	A11172-1	10PF 200V 5% NPO AXIAL CER T/R	F 5
C115	C10208-4	100 MF 25V 20% VERT ELEC	E 5
C116	C10208-4	100 MF 25V 20% VERT ELEC	E 4
C117	C 6804-6	0.1 MF 50V 10% CERM	E 3
C118	C 6804-6	0.1 MF 50V 10% CERM	E 3
C119	C 8897-8	0.1 MF 100V 20% CERM	E 3
C120	C 6804-6	0.1 MF 50V 10% CERM	F 3
C121	C 6804-6	0.1 MF 50V 10% CERM	F 3
C122	C 8897-8	0.1 MF 100V 20% CERM	G 3
C123	C10466-8	.22UF 50V 5% MTL FILM RDL T/A*	P 5
C124	C10505-3	.33UF 50V 5% MTL FILM RAD T/R	G 5
C125		OPEN	H 4
C126	C 6806-1	0.01 MF 100V AX CERM	H 4
C127	C10504-6	.18UF 50V 2% POLYPROP RADIAL	O 3
C128	A10579-103KC	0.01 MF 100V 10% POLY T/A	O 3
C129	A10579-103KC	0.01 MF 100V 10% POLY T/A	O 3
C130	A10434-104JD	0.1 MF 250V 5% MTL POLY	O 4
C131	126207-1	CAP. .1UF 50V 2.5% POLYPROP RDL	P 3
C132	A10434-104JD	0.1 MF 250V 5% MTL POLY	O 5
C133	A10434-473JD	0.047 MF 250V 5% POLY	O 5

**CROWN INTERNATIONAL INC.**

1718 WEST MISHAWAKA ROAD ELKHART, INDIANA 46517 PHONE (219) 294-8000

THESE DRAWINGS AND SPECIFICATIONS ARE THE PROPERTY OF CROWN INTERNATIONAL, INC. AND SHALL NOT BE REPRODUCED, COPIED, OR USED AS THE BASIS FOR THE MANUFACTURE OR SALE OF APPARATUS OR DEVICES WITHOUT PERMISSION.

DRAWN	KLW	8/19/98	DWG. NO.	SHEET 8 OF 22	REV
PROJ.	MD35050		100497-5		(B)

PARTS LIST			
REF DES	C.P.N.	DESCRIPTION	MAP LOC.
C134	A10434-473JD	0.047 MF 250V 5% POLY	O 5
C135	A10434-104JD	0.1 MF 250V 5% MTL POLY	P 5
C136	A10434-104JD	0.1 MF 250V 5% MTL POLY	P 5
C137	A10434-104JD	0.1 MF 250V 5% MTL POLY	P 5
C138	A10434-104JD	0.1 MF 250V 5% MTL POLY	P 5
C139	A10434-104JD	0.1 MF 250V 5% MTL POLY	O 6
C140	A10434-104JD	0.1 MF 250V 5% MTL POLY	N 6
C141	A10434-104JD	0.1 MF 250V 5% MTL POLY	N 5
C142	A10434-104JD	0.1 MF 250V 5% MTL POLY	N 5
C143	A10434-104JD	0.1 MF 250V 5% MTL POLY	N 5
C144	101025-1	0.015UF 50V 10% RAD CERM T/R	F 2
C145	C 7752-6	2.2 MF 50V NP 10% ELEC	G 2
C146	C 6802-0	.47 MF 50V AX CERM	F 2
C147	C 9161-8	0.01 MF 50V 10% RAD CERM	E 2
C148	C 8897-8	0.1 MF 100V 20% CERM	E 2
C149	C10208-4	100 MF 25V 20% VERT ELEC	E 2
C150	C10519-4	220.PF 200V 1% NPO RDL MLC T/R	F 2
C151	C10519-4	220.PF 200V 1% NPO RDL MLC T/R	E 2
C152	C10503-8	.0047UF 50V 5% POLYESTER T/R *	E 3
C153	C10520-2	0.001UF 50V 1% X7R RDL MLC T/R	G 2
C154	C10520-2	0.001UF 50V 1% X7R RDL MLC T/R	G 2
C155	C 8897-8	0.1 MF 100V 20% CERM	H 2
C156	C 7752-6	2.2 MF 50V NP 10% ELEC	I 4
C157	C 8897-8	0.1 MF 100V 20% CERM	J 5
C158	C 8897-8	0.1 MF 100V 20% CERM	J 5
C159	C 6807-9	0.001 MF 100V 10% AX CERM	J 6
C160	C 5362-6	2.2 MF 50V VERT	J 4
C161	C10208-4	100 MF 25V 20% VERT ELEC	J 5
C162	C 6806-1	0.01 MF 100V AX CERM	H 4
C163	C 6806-1	0.01 MF 100V AX CERM	G 4
C164	C 8897-8	0.1 MF 100V 20% CERM	G 4
C165	C 8897-8	0.1 MF 100V 20% CERM	G 3
C166	C10208-4	100 MF 25V 20% VERT ELEC	G 4
C167	C10208-4	100 MF 25V 20% VERT ELEC	G 4
C168	C 9615-3	680PF 100V 5% AXL CER NPO T/R	H 4
C169	C 9615-3	680PF 100V 5% AXL CER NPO T/R	G 4
C170	C 9161-8	0.01 MF 50V 10% RAD CERM	G 2
C171	C 6807-9	0.001 MF 100V 10% AX CERM	O 6
C172	C 6806-1	0.01 MF 100V AX CERM	G 5
C173	C 6812-9	47 PF 100V AX CERM	E 3
C174	C 6812-9	47 PF 100V AX CERM	F 3
C175	C10208-4	100 MF 25V 20% VERT ELEC	E 2
C176	C 6807-9	0.001 MF 100V 10% AX CERM	H 3
C177	C 6807-9	0.001 MF 100V 10% AX CERM	G 3
C200	A11172-1	10PF 200V 5% NPO AXIAL CER T/R	D 4
C201	C 6808-7	470 PF 100V AX CERM	D 4
C202	C10521-0	39.PF 50V 5% NPO RDL MLC T/R	D 4

<b>CROWN INTERNATIONAL INC.</b>			
1718 WEST MISHAWAKA ROAD		ELKHART, INDIANA 46517	PHONE (219) 294-8000
DRAWN	KLW	8/19/98	DWG. NO. 100497-5
PROJ.	MD350S0		SHEET 9 OF 22
			REV <b>(B)</b>

THESE DRAWINGS AND SPECIFICATIONS ARE THE PROPERTY OF CROWN INTERNATIONAL, INC. AND SHALL NOT BE REPRODUCED, COPIED, OR USED AS THE BASIS FOR THE MANUFACTURE OR SALE OF APPARATUS OR DEVICES WITHOUT PERMISSION.

PARTS LIST			
REF DES	C.P.N.	DESCRIPTION	MAP LOC.
C203	C10518-6	3300.PF 50V 1% X7R RDL MLC T/R	D 5
C204	C10518-6	3300.PF 50V 1% X7R RDL MLC T/R	D 5
C205	C 9621-1	100 PF 200V 5% AX CERM	D 4
C206	C10519-4	220.PF 200V 1% NPO RDL MLC T/R	D 4
C207	C 6807-9	0.001 MF 100V 10% AX CERM	B 4
C208	C10499-9	.047UF 50V 5% POLYESTER T/R *	B 5
C209	A10434-103JD	0.01 MF 250V 5% POLY	B 5
C210	A11172-1	10PF 200V 5% NPO AXIAL CER T/R	C 4
C211	100114-1	330PF 200V 5% AXIAL CER T/R	B 6
C212	C 6809-5	220 PF 100V 10% AX CERM	B 6
C213	A11172-1	10PF 200V 5% NPO AXIAL CER T/R	D 5
C214	A11172-1	10PF 200V 5% NPO AXIAL CER T/R	D 5
C215	C10208-4	100 MF 25V 20% VERT ELEC	C 5
C216	C10208-4	100 MF 25V 20% VERT ELEC	C 4
C217	C 6804-6	0.1 MF 50V 10% CERM	C 3
C218	C 6804-6	0.1 MF 50V 10% CERM	C 3
C219	C 8897-8	0.1 MF 100V 20% CERM	C 3
C220	C 6804-6	0.1 MF 50V 10% CERM	D 3
C221	C 6804-6	0.1 MF 50V 10% CERM	D 3
C222	C 8897-8	0.1 MF 100V 20% CERM	D 3
C223	C10466-8	.22UF 50V 5% MTL FILM RDL T/A*	L 5
C224	C10505-3	.33UF 50V 5% MTL FILM RAD T/R	G 5
C225		OPEN	H 6
C226	C 6806-1	0.01 MF 100V AX CERM	H 6
C227	C10504-6	.18UF 50V 2% POLYPROP RADIAL	L 3
C228	A10579-103KC	0.01 MF 100V 10% POLY T/A	L 3
C229	A10579-103KC	0.01 MF 100V 10% POLY T/A	L 3
C230	A10434-104JD	0.1 MF 250V 5% MTL POLY	M 4
C231	126207-1	CAP. .1UF 50V 2.5% POLYPROP RDL	L 3
C232	A10434-104JD	0.1 MF 250V 5% MTL POLY	L 5
C233	A10434-473JD	0.047 MF 250V 5% POLY	M 5
C234	A10434-473JD	0.047 MF 250V 5% POLY	M 5
C235	A10434-104JD	0.1 MF 250V 5% MTL POLY	K 5
C236	A10434-104JD	0.1 MF 250V 5% MTL POLY	K 5
C237	A10434-104JD	0.1 MF 250V 5% MTL POLY	K 5
C238	A10434-104JD	0.1 MF 250V 5% MTL POLY	K 5
C239	A10434-104JD	0.1 MF 250V 5% MTL POLY	L 6
C240	A10434-104JD	0.1 MF 250V 5% MTL POLY	M 6
C241	A10434-104JD	0.1 MF 250V 5% MTL POLY	M 5
C242	A10434-104JD	0.1 MF 250V 5% MTL POLY	M 5
C243	A10434-104JD	0.1 MF 250V 5% MTL POLY	M 5
C244	101025-1	0.015UF 50V 10% RAD CERM T/R	C 2
C245	C 7752-6	2.2 MF 50V NP 10% ELEC	B 2
C246	C 6802-0	.47 MF 50V AX CERM	C 2
C247	C 9161-8	0.01 MF 50V 10% RAD CERM	C 2
C248	C10208-4	100 MF 25V 20% VERT ELEC	D 2
C249	C 8897-8	0.1 MF 100V 20% CERM	E 2

**CROWN INTERNATIONAL INC.**

1718 WEST MISHAWAKA ROAD ELKHART, INDIANA 46517 PHONE (219) 294-8000

THESE DRAWINGS AND SPECIFICATIONS ARE THE PROPERTY OF CROWN INTERNATIONAL, INC AND SHALL NOT BE REPRODUCED, COPIED, OR USED AS THE BASIS FOR THE MANUFACTURE OR SALE OF APPARATUS OR DEVICES WITHOUT PERMISSION.

DRAWN	KLW	8/19/98	DWG. NO.	SHEET 10 OF 22	REV
PROJ.	MD35050		100497-5		(B)

PARTS LIST			
REF DES	C. P. N.	DESCRIPTION	MAP LOC.
C250	C10519-4	220.PF 200V 1% NPO RDL MLC T/R	D 2
C251	C10519-4	220.PF 200V 1% NPO RDL MLC T/R	D 2
C252	C10503-8	.0047UF 50V 5% POLYESTER T/R *	D 3
C253	C10520-2	0.001UF 50V 1% X7R RDL MLC T/R	B 2
C254	C10520-2	0.001UF 50V 1% X7R RDL MLC T/R	B 2
C255	C 8897-8	0.1 MF 100V 20% CERM	B 3
C256	C 7752-6	2.2 MF 50V NP 10% ELEC	I 5
C257	C 8897-8	0.1 MF 100V 20% CERM	A 5
C258	C 8897-8	0.1 MF 100V 20% CERM	B 5
C259	C 6807-9	0.001 MF 100V 10% AX CERM	A 6
C260	C 5362-6	2.2 MF 50V VERT	B 5
C261	C10208-4	100 MF 25V 20% VERT ELEC	A 5
C262	C 6806-1	0.01 MF 100V AX CERM	B 4
C263	C 6806-1	0.01 MF 100V AX CERM	A 4
C264	C 8897-8	0.1 MF 100V 20% CERM	B 4
C265	C 8897-8	0.1 MF 100V 20% CERM	A 3
C266	C10208-4	100 MF 25V 20% VERT ELEC	B 4
C267	C10208-4	100 MF 25V 20% VERT ELEC	B 4
C268	C 9615-3	680PF 100V 5% AXL CER NPO T/R	B 4
C269	C 9615-3	680PF 100V 5% AXL CER NPO T/R	A 4
C270	C 9161-8	0.01 MF 50V 10% RAD CERM	C 2
C271	C 6807-9	0.001 MF 100V 10% AX CERM	M 6
C272	C 6806-1	0.01 MF 100V AX CERM	B 5
C273	C 6812-9	47 PF 100V AX CERM	C 3
C274	C 6812-9	47 PF 100V AX CERM	D 3
C275	C10208-4	100 MF 25V 20% VERT ELEC	D 2
C276	C 6807-9	0.001 MF 100V 10% AX CERM	B 3
C277	C 6807-9	0.001 MF 100V 10% AX CERM	A 3
D1	C 2851-1	1N4004 SILICON RECT.	O 2
D2	C10463-5	DIODE, ULTRAFAST MUR120	N 2
D3	C10508-7	DIODE ULTRAFAST 4A 200V MUR420	M 2
D4	C 9738-3	BAT85 30V 200MA SCHOTTKY DIODE	O 2
D5	C 3181-2	1N4148 HI SPEED DIODE	P 2
D6	C 3181-2	1N4148 HI SPEED DIODE	O 2
D7	C 3533-4	1N966B 16 V ZENER	P 2
D8	C 8624-6	1N5818 SCHOTTKY RECT	P 2
D9	C 8624-6	1N5818 SCHOTTKY RECT	P 2
D10	C 8624-6	1N5818 SCHOTTKY RECT	Q 2
D11	C 8624-6	1N5818 SCHOTTKY RECT	Q 2
D12	C 8624-6	1N5818 SCHOTTKY RECT	L 1
D13	C 8624-6	1N5818 SCHOTTKY RECT	L 2
D14	C 9738-3	BAT85 30V 200MA SCHOTTKY DIODE	J 2
D15	C 9738-3	BAT85 30V 200MA SCHOTTKY DIODE	J 2
D16	C 9738-3	BAT85 30V 200MA SCHOTTKY DIODE	J 1
D17	C 9738-3	BAT85 30V 200MA SCHOTTKY DIODE	J 1
D18	C 3181-2	1N4148 HI SPEED DIODE	A 1
D19	C 3181-2	1N4148 HI SPEED DIODE	A 1

**CROWN INTERNATIONAL INC.**

1718 WEST MISHAWAKA ROAD ELKHART, INDIANA 46517 PHONE (219) 294-8000

THESE DRAWINGS AND SPECIFICATIONS ARE THE PROPERTY OF CROWN INTERNATIONAL, INC. AND SHALL NOT BE REPRODUCED, COPIED, OR USED AS THE BASIS FOR THE MANUFACTURE OR SALE OF APPARATUS OR DEVICES WITHOUT PERMISSION.

DRAWN	KLW	8/19/98	DWG. NO.	SHEET 11 OF 22	REV
PROJ.	MD35050		100497-5		(B)



PARTS LIST			
REF DES	C. P. N.	DESCRIPTION	MAP LOC.
D20	C 3181-2	1N4148 HI SPEED DIODE	A 1
D21	C 3181-2	1N4148 HI SPEED DIODE	A 1
D22	C 2851-1	1N4004 SILICON RECT.	I 3
D23	C 9929-8	TL431ACLP ADJ. PREC. RFNC	H 4
D24	C 3181-2	1N4148 HI SPEED DIODE	I 3
D25	C 3181-2	1N4148 HI SPEED DIODE	J 3
D26	C 3181-2	1N4148 HI SPEED DIODE	J 3
D27	C 3181-2	1N4148 HI SPEED DIODE	H 3
D100	C 3181-2	1N4148 HI SPEED DIODE	F 5
D101	C 3181-2	1N4148 HI SPEED DIODE	F 5
D106	C 3181-2	1N4148 HI SPEED DIODE	E 5
D107	C 9738-3	BAT85 30V 200MA SCHOTTKY DIODE	G 2
D108	C 3181-2	1N4148 HI SPEED DIODE	F 1
D110	C 3181-2	1N4148 HI SPEED DIODE	J 4
D111	C 3181-2	1N4148 HI SPEED DIODE	I 4
D112	C 3181-2	1N4148 HI SPEED DIODE	J 4
D113	C 9929-8	TL431ACLP ADJ. PREC. RFNC	H 4
D114	C 9929-8	TL431ACLP ADJ. PREC. RFNC	G 4
D115	C 9738-3	BAT85 30V 200MA SCHOTTKY DIODE	E 2
D116	C 9738-3	BAT85 30V 200MA SCHOTTKY DIODE	F 2
D117	C 3181-2	1N4148 HI SPEED DIODE	O 6
D118	C 3181-2	1N4148 HI SPEED DIODE	O 6
D119	C 3181-2	1N4148 HI SPEED DIODE	O 6
D120	C 3181-2	1N4148 HI SPEED DIODE	N 6
D200	C 3181-2	1N4148 HI SPEED DIODE	D 5
D201	C 3181-2	1N4148 HI SPEED DIODE	D 5
D206	C 3181-2	1N4148 HI SPEED DIODE	C 5
D207	C 9738-3	BAT85 30V 200MA SCHOTTKY DIODE	C 2
D208	C 3181-2	1N4148 HI SPEED DIODE	F 1
D210	C 3181-2	1N4148 HI SPEED DIODE	J 4
D211	C 3181-2	1N4148 HI SPEED DIODE	B 4
D212	C 3181-2	1N4148 HI SPEED DIODE	J 4
D213	C 9929-8	TL431ACLP ADJ. PREC. RFNC	B 4
D214	C 9929-8	TL431ACLP ADJ. PREC. RFNC	A 4
D215	C 9738-3	BAT85 30V 200MA SCHOTTKY DIODE	D 2
D216	C 9738-3	BAT85 30V 200MA SCHOTTKY DIODE	D 2
D217	C 3181-2	1N4148 HI SPEED DIODE	M 6
D218	C 3181-2	1N4148 HI SPEED DIODE	L 6
D219	C 3181-2	1N4148 HI SPEED DIODE	M 6
D220	C 3181-2	1N4148 HI SPEED DIODE	M 6
F1	C10602-8	FUSE, 1A 125V FAST T/R	L 2
HW1	102660-1	CLIP, DUAL TO220 VERTICAL	M 1
HW2	A10089-10606	6-32X3/8 PNHD PH MSCR Z	M 1
HW4	A10094-4	#6 INT STAR WASHER	M 1
HW6	A10102-5	6 X 32 HEX NUT	M 1
HW7	A10101-38	WSHR, PHEN .3150D X.145ID X.031	M 1
J2	D 9197-1	CABLE, MAIN TO INPUT K2/K1	E 6
J4	D 9196-3	CABLE, CONTROL TO MAIN K2/K1	I 2

**CROWN INTERNATIONAL INC.**

1718 WEST MISHAWAKA ROAD ELKHART, INDIANA 46517 PHONE (219) 294-8000

THESE DRAWINGS AND SPECIFICATIONS ARE THE PROPERTY OF CROWN INTERNATIONAL, INC. AND SHALL NOT BE REPRODUCED, COPIED, OR USED AS THE BASIS FOR THE MANUFACTURE OR SALE OF APPARATUS OR DEVICES WITHOUT PERMISSION.

DRAWN	KLW	B/19/98	DWG. NO.	SHEET 12 OF 22	REV
PROJ.	MD350S0		100497-5		(B)



PARTS LIST			
REF DES	C. P. N.	DESCRIPTION	MAP LOC.
J5		OPEN	H 1
J6	C10612-7	PC MOUNT SCREW TERMINAL	M 6
J7	C10612-7	PC MOUNT SCREW TERMINAL	N 6
J8	C10612-7	PC MOUNT SCREW TERMINAL	C 6
J101	D 8968-6	CABLE, MAIN TO OUTPUT	F 3
J201	D 8968-6	CABLE, MAIN TO OUTPUT	C 3
L1	C10496-5	INDUCTOR, 100UH 10% RADIAL T/R	L 2
L2	101015-1	INDUCTOR, 450UH 1AMP 0.2 OHM	N 1
L3	100112-1	INDUCTOR, 1UH RADIAL T/R	Q 1
L4	C10496-5	INDUCTOR, 100UH 10% RADIAL T/R	O 1
L5	C10496-5	INDUCTOR, 100UH 10% RADIAL T/R	P 2
L6	C10562-4	INDUCTOR, 22UH 10% RADIAL T/R	J 3
L100	C 5644-7	CHOKE, 33 UH 5%	G 6
L101	H43626-3	INDUCTOR, 2.03UH 30A	O 4
L102	125600-1	INDUCTOR, 1.01UH 30A AIRCORE	P 3
L103	125600-1	INDUCTOR, 1.01UH 30A AIRCORE	O 5
L104	125600-1	INDUCTOR, 1.01UH 30A AIRCORE	P 5
L200	C 5644-7	CHOKE, 33 UH 5%	B 6
L201	H43626-3	INDUCTOR, 2.03UH 30A	M 4
L202	125600-1	INDUCTOR, 1.01UH 30A AIRCORE	K 3
L203	125600-1	INDUCTOR, 1.01UH 30A AIRCORE	L 5
L204	125600-1	INDUCTOR, 1.01UH 30A AIRCORE	K 5
P3	C10596-2	MATE-N-LOK MINI 24POS VERT HDR	M 3
P101	101031-1	.250 FASTON, AUTO INSERTABLE	Q 6
P201	101031-1	.250 FASTON, AUTO INSERTABLE	K 6
P100A	101031-1	.250 FASTON, AUTO INSERTABLE	O 5
P100B	101031-1	.250 FASTON, AUTO INSERTABLE	O 5
P200A	101031-1	.250 FASTON, AUTO INSERTABLE	M 5
P200B	101031-1	.250 FASTON, AUTO INSERTABLE	M 5
Q1	C 3625-8	2N4125 30V PNP T/R	N 3
Q2	C10511-1	MOSFET, N-CH 200V MTP7N20E	M 2
Q3	100972-1	MOSFET, P-CH -60V SSP2955	P 1
Q4	C10510-3	MOSFET, N-CH 60V MTP3055V	P 1
Q5	C 7458-0	2N4123 30V NPN T/R	A 1
Q6	C10513-7	SCR, 400V 8A MCR72-6	J 2
Q7	C 7458-0	2N4123 30V NPN T/R	J 3
Q8	C 3810-6	MPSA42 300V NPN T/R	J 3
Q9	C 3578-9	MPSA93 200V PNP T/R	J 3
Q10	C 3578-9	MPSA93 200V PNP T/R	J 3
Q100	C 7458-0	2N4123 30V NPN T/R	F 5
Q101	C 3625-8	2N4125 30V PNP T/R	F 5
Q102	C 7458-0	2N4123 30V NPN T/R	I 5
Q200	C 7458-0	2N4123 30V NPN T/R	D 5
Q201	C 3625-8	2N4125 30V PNP T/R	D 5
Q202	C 7458-0	2N4123 30V NPN T/R	A 5
R1	A10265-35711	3.57K 0.25W 1% MF	O 2
R2	A10265-22121	22.1K 0.25W 1% MF	O 2

<b>CROWN INTERNATIONAL INC.</b>			
1718 WEST MISHAWAKA ROAD		ELKHART, INDIANA 46517	PHONE (219) 294-8000
DRAWN	KLW	8/19/98	DWG. NO.
PROJ.	MD350S0	100497-5	SHEET 13 OF 22
			REV <b>(B)</b>

THESE DRAWINGS AND SPECIFICATIONS ARE THE PROPERTY OF CROWN INTERNATIONAL, INC. AND SHALL NOT BE REPRODUCED, COPIED, OR USED AS THE BASIS FOR THE MANUFACTURE OR SALE OF APPARATUS OR DEVICES WITHOUT PERMISSION.

PARTS LIST			
REF DES	C. P. N.	DESCRIPTION	MAP LOC.
R3	A10265-49911	4.99K 0.25W 1% MF	N 2
R4	A10265-24921	24.9K 0.25W 1% MF	O 2
R5	A10266-4732	47K 0.50W 5% CF	M 2
R6	A10265-10021	10K 0.25W 1% MF	N 2
R7	A10265-30121	30.1K 0.25W 1% MF	N 2
R8	A10265-10021	10K 0.25W 1% MF	N 2
R9	A10265-10001	100 OHM 0.25W 1% MF	O 2
R10	A10266-1R02	1 0.50W 5% CF	O 1
R11	A10266-1R02	1 0.50W 5% CF	O 1
R12	A10266-1R02	1 0.50W 5% CF	N 1
R13	A10266-4701	47 OHM 0.25W 5% CF	N 2
R14		OPEN	N 2
R15	A10265-10011	1K 0.25W 1% MF	P 2
R16	A10265-10021	10K 0.25W 1% MF	O 2
R17	A10265-10R01	10 OHM 0.25W 1% MF	P 2
R18	A10265-10R01	10 OHM 0.25W 1% MF	P 2
R19	A10265-10001	100 OHM 0.25W 1% MF	H 2
R20	A10265-10001	100 OHM 0.25W 1% MF	A 1
R21	A10265-49911	4.99K 0.25W 1% MF	A 1
R22	A10265-20031	200K 0.25W 1% MF	I 2
R23	A10265-20031	200K 0.25W 1% MF	H 1
R24	A10265-49911	4.99K 0.25W 1% MF	B 1
R25	A10265-10021	10K 0.25W 1% MF	A 2
R26	A10265-10001	100 OHM 0.25W 1% MF	D 1
R27	A10265-10041	1M 0.25W 1% MF	D 1
R28	A10265-20011	2K 0.25W 1% MF	D 1
R29	C10492-4	100 OHM 3W 5% METAL OXIDE T/R	J 2
R30	C10492-4	100 OHM 3W 5% METAL OXIDE T/R	J 2
R31	C10492-4	100 OHM 3W 5% METAL OXIDE T/R	I 2
R32	C10492-4	100 OHM 3W 5% METAL OXIDE T/R	I 2
R33	C10492-4	100 OHM 3W 5% METAL OXIDE T/R	I 2
R34	C10492-4	100 OHM 3W 5% METAL OXIDE T/R	I 2
R35	C10492-4	100 OHM 3W 5% METAL OXIDE T/R	I 2
R36	A10265-20011	2K 0.25W 1% MF	J 2
R37	A10265-10011	1K 0.25W 1% MF	I 2
R38	A10265-10011	1K 0.25W 1% MF	I 2
R39	A10265-10011	1K 0.25W 1% MF	I 2
R40	A10265-10031	100K 0.25W 1% MF	J 3
R41	A10265-20021	20K 0.25W 1% MF	J 3
R42	A10265-20031	200K 0.25W 1% MF	J 2
R43	A10265-10021	10K 0.25W 1% MF	G 1
R44	A10265-10021	10K 0.25W 1% MF	G 1
R45	A10265-10021	10K 0.25W 1% MF	I 3
R46	A10265-45331	453K 0.25W 1% MF	I 3
R47	A10265-20031	200K 0.25W 1% MF	I 3
R48	A10265-20031	200K 0.25W 1% MF	I 3
R49	A10265-12741	1.27M 0.25W 1% MF	I 4

**CROWN INTERNATIONAL INC.**

1718 WEST MISHAWAKA ROAD ELKHART, INDIANA 46517 PHONE (219) 294-0000

THESE DRAWINGS AND SPECIFICATIONS ARE THE PROPERTY OF CROWN INTERNATIONAL, INC. AND SHALL NOT BE REPRODUCED, COPIED, OR USED AS THE BASIS FOR THE MANUFACTURE OR SALE OF APPARATUS OR DEVICES WITHOUT PERMISSION.

DRAWN	KLW	8/19/98	DWG. NO.	SHEET 14 OF 22	REV
PROJ.	MD35050		100497-5		(B)

PARTS LIST			
REF DES	C. P. N.	DESCRIPTION	MAP LOC.
R51	A10265-20021	20K 0.25W 1% MF	I 4
R53	A10265-33211	3.32K 0.25W 1% MF	J 3
R54	A10265-10011	1K 0.25W 1% MF	J 3
R55	A10265-39211	3.92K 0.25W 1% MF	J 3
R56	A10265-24321	24.3K 0.25W 1% MF	J 3
R57	A10265-19121	19.1K 0.25W 1% MF	J 4
R59	A10265-20021	20K 0.25W 1% MF	H 3
R60	A10265-10021	10K 0.25W 1% MF	H 4
R100	A10265-49911	4.99K 0.25W 1% MF	F 4
R101	A10265-56211	5.62K 0.25W 1% MF	F 4
R102	A10265-10021	10K 0.25W 1% MF	G 5
R103	A10265-10021	10K 0.25W 1% MF	F 5
R104	A10265-10011	1K 0.25W 1% MF	E 4
R105	A10265-10031	100K 0.25W 1% MF	F 4
R106	A10265-24321	24.3K 0.25W 1% MF	F 4
R107	A10265-75011	7.5K 0.25W 1% MF	F 4
R108	A10265-10011	1K 0.25W 1% MF	G 5
R109	A10265-10021	10K 0.25W 1% MF	E 4
R110	C 9639-3	4.99K 0.40W 0.1% MF	E 4
R111	C 9639-3	4.99K 0.40W 0.1% MF	E 4
R112	A10265-22111	2.21K 0.25W 1% MF	E 3
R113	A10265-11011	1.1K 0.25W 1% MF	E 3
R114	A10265-10011	1K 0.25W 1% MF	F 5
R115	A10265-10011	1K 0.25W 1% MF	F 5
R116	A10265-10011	1K 0.25W 1% MF	F 5
R117	A10265-10011	1K 0.25W 1% MF	F 5
R118	A10265-10021	10K 0.25W 1% MF	G 5
R119	A10265-10021	10K 0.25W 1% MF	F 5
R120	A10265-10021	10K 0.25W 1% MF	F 5
R121	A10265-10021	10K 0.25W 1% MF	E 5
R122	A10265-10021	10K 0.25W 1% MF	E 5
R123	A10265-10021	10K 0.25W 1% MF	F 5
R124	A10265-22111	2.21K 0.25W 1% MF	F 3
R125	A10265-11011	1.1K 0.25W 1% MF	F 3
R126	A10265-26721	26.7K 0.25W 1% MF	E 5
R127	A10265-10021	10K 0.25W 1% MF	E 5
R128	A10265-26721	26.7K 0.25W 1% MF	E 5
R129	A10265-10021	10K 0.25W 1% MF	E 5
R130	A10265-20021	20K 0.25W 1% MF	E 5
R131	A10265-10001	100 OHM 0.25W 1% MF	E 3
R132	A10265-10001	100 OHM 0.25W 1% MF	E 3
R133	A10265-10001	100 OHM 0.25W 1% MF	F 3
R134	A10265-10001	100 OHM 0.25W 1% MF	F 3
R135	A10265-10011	1K 0.25W 1% MF	G 3
R136	A10266-3301	33 OHM 0.25W 5% CF	K 2
R137	A10265-23201	232 OHM 0.25W 1% MF	P 6
R138	100269-1	1 OHM 0.50W 1% MF .25W BODY	G 5

<b>CROWN INTERNATIONAL INC.</b>			
1718 WEST MISHAWAKA ROAD		ELKHART, INDIANA 46517	PHONE (219) 294-8000
THESE DRAWINGS AND SPECIFICATIONS ARE THE PROPERTY OF CROWN INTERNATIONAL, INC. AND SHALL NOT BE REPRODUCED, COPIED, OR USED AS THE BASIS FOR THE MANUFACTURE OR SALE OF APPARATUS OR DEVICES WITHOUT PERMISSION.	DRAWN	KLW 8/19/98	DWG. NO. 100497-5
	PROJ.	MD35050	SHEET 15 OF 22
			REV (B)

PARTS LIST			
REF DES	C. P. N.	DESCRIPTION	MAP LOC.
R139	A10265-10711	1.07K 0.25W 1% MF	H 4
R140	A10265-15031	150K 0.25W 1% MF	H 4
R141	A10265-20021	20K 0.25W 1% MF	H 4
R142	A10265-10001	100 OHM 0.25W 1% MF	H 4
R143	A10265-20031	200K 0.25W 1% MF	G 4
R144	A10265-12741	1.27M 0.25W 1% MF	H 4
R145	A10265-35711	3.57K 0.25W 1% MF	I 4
R146	C10540-0	10K TOP ADJUST TRIMMER T/R	J 5
R147	A10265-10011	1K 0.25W 1% MF	P 6
R148	A10266-1R01	1 0.25W 5% CF	P 6
R149	100116-1	39 OHM 2W 5% CF T/R (1W BODY)	N 5
R150	100116-1	39 OHM 2W 5% CF T/R (1W BODY)	N 5
R151	100116-1	39 OHM 2W 5% CF T/R (1W BODY)	N 4
R152	100116-1	39 OHM 2W 5% CF T/R (1W BODY)	N 4
R153	100117-1	8.20HM 1W 5% CF T/R (.5W BODY)	O 4
R154	100117-1	8.20HM 1W 5% CF T/R (.5W BODY)	O 4
R155	100117-1	8.20HM 1W 5% CF T/R (.5W BODY)	O 4
R156	100116-1	39 OHM 2W 5% CF T/R (1W BODY)	O 5
R157	100116-1	39 OHM 2W 5% CF T/R (1W BODY)	P 5
R158	100116-1	39 OHM 2W 5% CF T/R (1W BODY)	P 5
R159	100116-1	39 OHM 2W 5% CF T/R (1W BODY)	P 5
R160	A10265-12741	1.27M 0.25W 1% MF	J 4
R161	A10265-20022	20K 0.50W 1% MF	H 2
R162	A10265-20022	20K 0.50W 1% MF	H 2
R163	A10265-10031	100K 0.25W 1% MF	G 2
R164	A10265-82521	82.5K 0.25W 1% MF	G 2
R165	A10265-20022	20K 0.50W 1% MF	H 2
R166	A10265-20022	20K 0.50W 1% MF	H 2
R167	A10265-30921	30.9K 0.25W 1% MF	H 2
R168	A10265-10021	10K 0.25W 1% MF	F 1
R169	A10265-10011	1K 0.25W 1% MF	F 2
R170	A10265-18211	1.82K 0.25W 1% MF	G 2
R171	A10265-11021	11K 0.25W 1% MF	F 2
R172	A10265-10021	10K 0.25W 1% MF	G 2
R173	A10265-10021	10K 0.25W 1% MF	F 2
R174	A10265-20011	2K 0.25W 1% MF	F 2
R175	A10265-10021	10K 0.25W 1% MF	E 2
R176	A10265-68121	68.1K 0.25W 1% MF	E 2
R177	A10265-24321	24.3K 0.25W 1% MF	F 2
R178	A10265-64921	64.9K 0.25W 1% MF	E 2
R179	A10265-82511	8.25K 0.25W 1% MF	E 2
R180	A10265-10011	1K 0.25W 1% MF	E 2
R181	A10265-20021	20K 0.25W 1% MF	F 2
R182	A10265-66511	6.65K 0.25W 1% MF	F 2
R183	A10265-46411	4.64K 0.25W 1% MF	F 2
R184	A10265-46411	4.64K 0.25W 1% MF	F 1
R185	A10265-10021	10K 0.25W 1% MF	G 1

**CROWN INTERNATIONAL INC.**

1718 WEST MISHAWAKA ROAD ELKHART, INDIANA 46517 PHONE (219) 294-8000

THESE DRAWINGS AND SPECIFICATIONS ARE THE PROPERTY OF CROWN INTERNATIONAL, INC. AND SHALL NOT BE REPRODUCED, COPIED, OR USED AS THE BASIS FOR THE MANUFACTURE OR SALE OF APPARATUS OR DEVICES WITHOUT PERMISSION.

DRAWN	KLW	8/19/98	DWG. NO.	SHEET 16 OF 22	REV
PROJ.	MD35050		100497-5		(B)

PARTS LIST			
REF DES	C.P.N.	DESCRIPTION	MAP LOC.
R186	A10265-10021	10K 0.25W 1% MF	G 1
R187	A10265-11311	1.13K 0.25W 1% MF	G 1
R188	A10265-10011	1K 0.25W 1% MF	G 2
R189	A10265-10021	10K 0.25W 1% MF	G 2
R191	A10265-51131	511K 0.25W 1% MF	I 6
R192	A10265-10031	100K 0.25W 1% MF	I 4
R193	A10265-22111	2.21K 0.25W 1% MF	E 2
R194	A10265-20021	20K 0.25W 1% MF	J 6
R195	A10266-2241	220K 0.25W 5% CF	J 6
R196	A10265-10021	10K 0.25W 1% MF	I 6
R197	A10265-10031	100K 0.25W 1% MF	I 4
R198	A10265-12121	12.1K 0.25W 1% MF	I 6
R199	A10265-10021	10K 0.25W 1% MF	I 6
R200	A10265-49911	4.99K 0.25W 1% MF	D 4
R201	A10265-56211	5.62K 0.25W 1% MF	D 4
R202	A10265-10021	10K 0.25W 1% MF	D 5
R203	A10265-10021	10K 0.25W 1% MF	D 5
R204	A10265-10011	1K 0.25W 1% MF	C 4
R205	A10265-10031	100K 0.25W 1% MF	C 4
R206	A10265-24321	24.3K 0.25W 1% MF	D 4
R207	A10265-75011	7.5K 0.25W 1% MF	D 4
R208	A10265-10011	1K 0.25W 1% MF	B 5
R209	A10265-10021	10K 0.25W 1% MF	C 4
R210	C 9639-3	4.99K 0.40W 0.1% MF	C 4
R211	C 9639-3	4.99K 0.40W 0.1% MF	C 4
R212	A10265-22111	2.21K 0.25W 1% MF	C 3
R213	A10265-11011	1.1K 0.25W 1% MF	C 3
R214	A10265-10011	1K 0.25W 1% MF	D 5
R215	A10265-10011	1K 0.25W 1% MF	D 5
R216	A10265-10011	1K 0.25W 1% MF	D 5
R217	A10265-10011	1K 0.25W 1% MF	D 5
R218	A10265-10021	10K 0.25W 1% MF	D 5
R219	A10265-10021	10K 0.25W 1% MF	D 5
R220	A10265-10021	10K 0.25W 1% MF	C 5
R221	A10265-10021	10K 0.25W 1% MF	C 5
R222	A10265-10021	10K 0.25W 1% MF	C 5
R223	A10265-10021	10K 0.25W 1% MF	D 5
R224	A10265-22111	2.21K 0.25W 1% MF	D 3
R225	A10265-11011	1.1K 0.25W 1% MF	D 3
R226	A10265-26721	26.7K 0.25W 1% MF	C 5
R227	A10265-10021	10K 0.25W 1% MF	C 5
R228	A10265-26721	26.7K 0.25W 1% MF	C 5
R229	A10265-10021	10K 0.25W 1% MF	C 5
R230	A10265-20021	20K 0.25W 1% MF	C 5
R231	A10265-10001	100 OHM 0.25W 1% MF	C 3
R232	A10265-10001	100 OHM 0.25W 1% MF	C 3
R233	A10265-10001	100 OHM 0.25W 1% MF	D 3

<b>CROWN INTERNATIONAL INC.</b>			
1718 WEST MISHAWAKA ROAD		ELKHART, INDIANA 46517	PHONE (219) 294-8000
THESE DRAWINGS AND SPECIFICATIONS ARE THE PROPERTY OF CROWN INTERNATIONAL, INC. AND SHALL NOT BE REPRODUCED, COPIED, OR USED AS THE BASIS FOR THE MANUFACTURE OR SALE OF APPARATUS OR DEVICES WITHOUT PERMISSION.	DRAWN	KLW	8/19/98
	PROJ.	MD350S0	DWG. NO. 100497-5
			SHEET 17 OF 22
			REV (B)

PARTS LIST			
REF DES	C. P. N.	DESCRIPTION	MAP LOC.
R234	A10265-10001	100 OHM 0.25W 1% MF	D 3
R235	A10265-10011	1K 0.25W 1% MF	B 3
R236	A10266-3301	33 OHM 0.25W 5% CF	K 2
R237	A10265-23201	232 OHM 0.25W 1% MF	K 6
R238	100269-1	1 OHM 0.50W 1% MF .25W BODY	B 5
R239	A10265-10711	1.07K 0.25W 1% MF	H 6
R240	A10265-15031	150K 0.25W 1% MF	H 6
R241	A10265-20021	20K 0.25W 1% MF	H 6
R242	A10265-10001	100 OHM 0.25W 1% MF	H 6
R243	A10265-20031	200K 0.25W 1% MF	G 6
R244	A10265-12741	1.27M 0.25W 1% MF	H 6
R245	A10265-35711	3.57K 0.25W 1% MF	H 6
R246	C10540-0	10K TOP ADJUST TRIMMER T/R	J 5
R247	A10265-10011	1K 0.25W 1% MF	K 6
R248	A10266-1R01	1 0.25W 5% CF	K 6
R249	100116-1	39 OHM 2W 5% CF T/R (1W BODY)	N 5
R250	100116-1	39 OHM 2W 5% CF T/R (1W BODY)	M 5
R251	100116-1	39 OHM 2W 5% CF T/R (1W BODY)	N 4
R252	100116-1	39 OHM 2W 5% CF T/R (1W BODY)	M 4
R253	100117-1	8.20HM 1W 5% CF T/R (.5W BODY)	M 4
R254	100117-1	8.20HM 1W 5% CF T/R (.5W BODY)	L 4
R255	100117-1	8.20HM 1W 5% CF T/R (.5W BODY)	L 4
R256	100116-1	39 OHM 2W 5% CF T/R (1W BODY)	L 5
R257	100116-1	39 OHM 2W 5% CF T/R (1W BODY)	L 5
R258	100116-1	39 OHM 2W 5% CF T/R (1W BODY)	L 5
R259	100116-1	39 OHM 2W 5% CF T/R (1W BODY)	K 5
R260	A10265-12741	1.27M 0.25W 1% MF	A 4
R261	A10265-20022	20K 0.50W 1% MF	A 2
R262	A10265-20022	20K 0.50W 1% MF	A 2
R263	A10265-10031	100K 0.25W 1% MF	B 3
R264	A10265-82521	82.5K 0.25W 1% MF	B 3
R265	A10265-20022	20K 0.50W 1% MF	A 2
R266	A10265-20022	20K 0.50W 1% MF	A 2
R267	A10265-30921	30.9K 0.25W 1% MF	B 2
R268	A10265-10021	10K 0.25W 1% MF	F 1
R269	A10265-10011	1K 0.25W 1% MF	C 2
R270	A10265-18211	1.82K 0.25W 1% MF	C 2
R271	A10265-11021	11K 0.25W 1% MF	C 2
R272	A10265-10021	10K 0.25W 1% MF	C 2
R273	A10265-10021	10K 0.25W 1% MF	C 2
R274	A10265-20011	2K 0.25W 1% MF	C 2
R275	A10265-10021	10K 0.25W 1% MF	D 2
R276	A10265-68121	68.1K 0.25W 1% MF	D 2
R277	A10265-24321	24.3K 0.25W 1% MF	C 2
R278	A10265-64921	64.9K 0.25W 1% MF	D 2
R279	A10265-82511	8.25K 0.25W 1% MF	D 2
R280	A10265-10011	1K 0.25W 1% MF	D 2

**CROWN INTERNATIONAL INC.**

1718 WEST MISHAWAKA ROAD ELKHART, INDIANA 46517 PHONE (219) 294-8000

THESE DRAWINGS AND SPECIFICATIONS ARE THE PROPERTY OF CROWN INTERNATIONAL, INC. AND SHALL NOT BE REPRODUCED, COPIED, OR USED AS THE BASIS FOR THE MANUFACTURE OR SALE OF APPARATUS OR DEVICES WITHOUT PERMISSION.

DRAWN	KLW	8/19/98	DWG. NO.	SHEET 18 OF 22	REV
PROJ.	MD35050		100497-5		(B)



PARTS LIST			
REF DES	C. P. N.	DESCRIPTION	MAP LOC.
R281	A10265-20021	20K 0.25W 1% MF	D 2
R282	A10265-66511	6.65K 0.25W 1% MF	D 2
R283	A10265-46411	4.64K 0.25W 1% MF	C 2
R284	A10265-46411	4.64K 0.25W 1% MF	C 1
R285	A10265-10021	10K 0.25W 1% MF	B 1
R286	A10265-10021	10K 0.25W 1% MF	B 1
R287	A10265-11311	1.13K 0.25W 1% MF	B 1
R288	A10265-10011	1K 0.25W 1% MF	A 3
R289	A10265-10021	10K 0.25W 1% MF	B 3
R291	A10265-51131	511K 0.25W 1% MF	I 6
R292	A10265-10031	100K 0.25W 1% MF	I 6
R293	A10265-22111	2.21K 0.25W 1% MF	E 2
R294	A10265-20021	20K 0.25W 1% MF	B 6
R295	A10266-2241	220K 0.25W 5% CF	B 6
R296	A10265-10021	10K 0.25W 1% MF	A 6
R297	A10265-10031	100K 0.25W 1% MF	A 4
R298	A10265-12121	12.1K 0.25W 1% MF	A 6
R299	A10265-10021	10K 0.25W 1% MF	A 6
R300	A10265-20021	20K 0.25W 1% MF	I 4
R301	A10265-10031	100K 0.25W 1% MF	I 4
R302	A10265-10011	1K 0.25W 1% MF	I 4
R303	A10265-12111	1.21K 0.25W 1% MF	H 4
R304	A10265-51111	5.11K 0.25W 1% MF	H 4
R305	A10265-20011	2K 0.25W 1% MF	H 4
R306	A10265-10011	1K 0.25W 1% MF	H 3
R307	A10265-10011	1K 0.25W 1% MF	G 3
R308	A10265-20011	2K 0.25W 1% MF	G 4
R309	A10265-51111	5.11K 0.25W 1% MF	G 4
R310	A10265-12111	1.21K 0.25W 1% MF	G 4
R311	A10265-15011	1.5K 0.25W 1% MF	H 3
R313	A10266-1061	10M 0.25W 5% CF	H 3
R314	A10265-10011	1K 0.25W 1% MF	H 4
R315	A10265-10011	1K 0.25W 1% MF	G 4
R316	A10266-1061	10M 0.25W 5% CF	G 3
R317	A10265-10011	1K 0.25W 1% MF	H 4
R318	A10265-10011	1K 0.25W 1% MF	G 4
R319	A10266-3932	39K 0.50W 5% CF	O 5
R320	A10266-3301	33 OHM 0.25W 5% CF	G 5
R321		OPEN	G 5
R322	A10265-20011	2K 0.25W 1% MF	E 3
R323	A10265-20011	2K 0.25W 1% MF	F 3
R324		OPEN	E 2
R400	A10265-20021	20K 0.25W 1% MF	A 4
R401	A10265-10031	100K 0.25W 1% MF	J 4
R402	A10265-10011	1K 0.25W 1% MF	A 4
R403	A10265-12111	1.21K 0.25W 1% MF	B 4
R404	A10265-51111	5.11K 0.25W 1% MF	B 4

**CROWN INTERNATIONAL INC.**

1718 WEST MISHAWAKA ROAD ELKHART, INDIANA 46517 PHONE (219) 294-8000

THESE DRAWINGS AND SPECIFICATIONS ARE THE PROPERTY OF CROWN INTERNATIONAL, INC. AND SHALL NOT BE REPRODUCED, COPIED, OR USED AS THE BASIS FOR THE MANUFACTURE OR SALE OF APPARATUS OR DEVICES WITHOUT PERMISSION.

DRAWN	KLW	8/19/98	DWG. NO.	SHEET 19 OF 22	REV
PROJ.	MD350S0		100497-5		(B)

PARTS LIST			
REF DES	C. P. N.	DESCRIPTION	MAP LOC.
R405	A10265-20011	2K 0.25W 1% MF	B 4
R406	A10265-10011	1K 0.25W 1% MF	B 3
R407	A10265-10011	1K 0.25W 1% MF	A 3
R408	A10265-20011	2K 0.25W 1% MF	A 4
R409	A10265-51111	5.11K 0.25W 1% MF	A 4
R410	A10265-12111	1.21K 0.25W 1% MF	A 4
R411	A10265-15011	1.5K 0.25W 1% MF	B 3
R413	A10266-1061	10M 0.25W 5% CF	B 3
R414	A10265-10011	1K 0.25W 1% MF	B 4
R415	A10265-10011	1K 0.25W 1% MF	A 4
R416	A10266-1061	10M 0.25W 5% CF	A 3
R417	A10265-10011	1K 0.25W 1% MF	B 4
R418	A10265-10011	1K 0.25W 1% MF	A 4
R419	A10266-3932	39K 0.50W 5% CF	L 5
R420	A10266-3301	33 OHM 0.25W 5% CF	B 5
R421		OPEN	B 5
R422	A10265-20011	2K 0.25W 1% MF	C 3
R423	A10265-20011	2K 0.25W 1% MF	D 3
R424		OPEN	D 2
T1	125102-1	XFMR, K SERIES LOW VOLTAGE	L 2
T100	H43628-9	XFMR, 100:1 CURRENT SENSE	P 4
T100X	102660-1	WIRE, K2 CURRENT SENSE	P 4
T200	H43628-9	XFMR, 100:1 CURRENT SENSE	K 4
T200X	102660-1	WIRE, K2 CURRENT SENSE	K 4
TP1		OPEN	J 1
TP2	C 9896-9	TEST POINT LOOP	E 4
TP100	C 9896-9	TEST POINT LOOP	F 4
TP101	C 9896-9	TEST POINT LOOP	E 4
TP102	C 9896-9	TEST POINT LOOP	F 2
TP103	C 9896-9	TEST POINT LOOP	O 4
TP104	C 9896-9	TEST POINT LOOP	F 4
TP200	C 9896-9	TEST POINT LOOP	D 4
TP201	C 9896-9	TEST POINT LOOP	C 4
TP202	C 9896-9	TEST POINT LOOP	D 2
TP203	C 9896-9	TEST POINT LOOP	L 4
TP204	C 9896-9	TEST POINT LOOP	D 4
U1	C 4696-8	TL074CN QUAD OP AMP	H 5
U2	C 7558-7	MC33079P QUAD LO NOISE OP AMP	G 2
U3	C 7558-7	MC33079P QUAD LO NOISE OP AMP	B 2
U4	C 8075-1	LM78L05ACZ POS 5VOLT REG	D 1
U5	C10469-2	74HC4024N 7 STAGE COUNTER *	C 2
U6	100113-1	74AC02 QUAD 2 INPUT NOR GATE	E 2
U7	C 4345-2	QUAD VOLTAGE COMPARATOR	I 3
U8	C 4345-2	QUAD VOLTAGE COMPARATOR	J 4
U9	C10500-4	UC3842, SWITCH SUPPLY CONTRL	N 3
U10	C10512-9	MOS GATE DVR, IR2117	N 2
U11	C 8613-9	MC34151P HISP D DUAL MOSFET DVR	P 2

**CROWN INTERNATIONAL INC.**

1718 WEST MISHAWAKA ROAD ELKHART, INDIANA 46517 PHONE (219) 294-8000

THESE DRAWINGS AND SPECIFICATIONS ARE THE PROPERTY OF CROWN INTERNATIONAL, INC. AND SHALL NOT BE REPRODUCED, COPIED, OR USED AS THE BASIS FOR THE MANUFACTURE OR SALE OF APPARATUS OR DEVICES WITHOUT PERMISSION.

DRAWN	KLW	8/19/98	DWG. NO.	SHEET 20 OF 22	REV
PROJ.	MD35050		100497-5		(B)





This Page Intentionally Left Blank

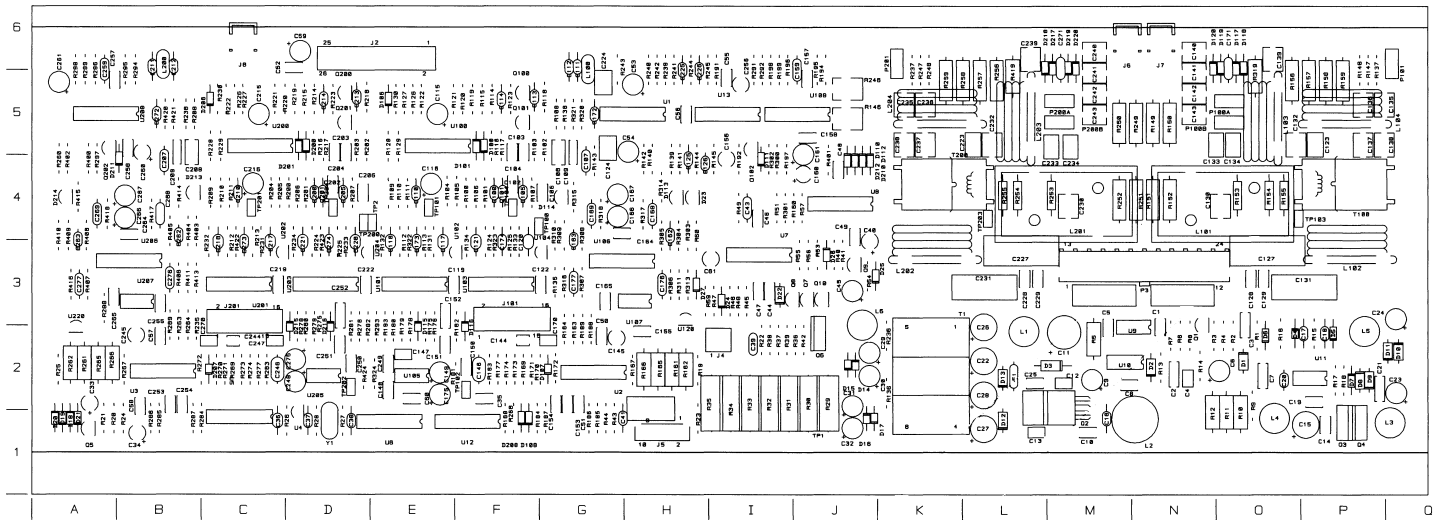

100497-5 PWA Component Map (Component Side)



This Page Intentionally Left Blank

E. C.	ZONE	REV.	DESCRIPTION	DATE	BY	APPROVALS			
						CHK	CM	EE	PE
		A	INITIAL RELEASE FOR PRODUCTION (LEVEL 1)	03-17-99	JAW	JM		ER	ER

NOTES:

1. SCHEMATIC DRAWING NUMBER 100522.
2. PRINTED WIRING BOARD PART NUMBER 100523-7.



**CAUTION**

STATIC CAN DAMAGE COMPONENTS!

**DO NOT HANDLE**

UNLESS WRIST STRAP IS WORN

THESE DRAWINGS AND SPECIFICATIONS ARE THE PROPERTY OF CROWN INTERNATIONAL, INC. AND SHALL NOT BE REPRODUCED, COPIED, OR USED AS THE BASIS FOR THE MANUFACTURE OR SALE OF APPARATUS OR DEVICES WITHOUT PERMISSION.

<b>CROWN INTERNATIONAL INC.</b>	
PRINTS TO	1718 WEST MISHAWAKA ROAD ELKHART, INDIANA 46517 PHONE (219) 294-8000
K	PWA, INPUT K2
	TOL. UNLESS SPECIFIED X.XX = ± 0.020 X.XXX = ± 0.010 DRILLS = ± 0.003
DRAWN	JAW 03-17-99 APPROVED BY: DO NOT SCALE PRINT
CHECKED	JM 3-18-99 ME CW 3-19-99 SUPERSEDES
SCALE	NONE EE ER 3-19-99 E.C.N.
PROJ	MD350D0 PE ER 03-18-99 C.P.N. SHEET 1 OF 12
FILENAME: 100524-6_A-01.PCB	
	100524-6 (A)

PARTS LIST			
REF DES	C. P. N.	DESCRIPTION	MAP LOC.
C1	C 8897-8	.1UF 100V 20% Z5U RAD CER T/R	F 4
C2	C10516-0	470.UF 10V 20% LOW ESR RDL T/R	D 4
C3	C 8897-8	.1UF 100V 20% Z5U RAD CER T/R	H 3
C4	C 6802-0	.47UF 50V AXIAL CER T/R 474	A 4
C5	C 9620-3	47PF 200V 5% AXIAL CER NPO T/R	A 4
C6	C 5362-6	2.2UF 50V VERT ELECT T/A	G 4
C7	C10208-4	100.UF 25V 20% RAD ELECT T/R	G 2
C100	C 9161-8	.01 UF 50V 10% X7R RAD CER T/R	F 5
C101	101323-1	22PF 50V 10% N220 DISC T/R	D 4
C102	101323-1	22PF 50V 10% N220 DISC T/R	D 4
C103	C 5362-6	2.2UF 50V VERT ELECT T/A	H 5
C104	C 6802-0	.47UF 50V AXIAL CER T/R 474	H 5
C105	C 9161-8	.01 UF 50V 10% X7R RAD CER T/R	F 4
C106	C 9465-3	10UF 50V 20% VERT ELECT T/A	D 3
C107	101323-1	22PF 50V 10% N220 DISC T/R	D 4
C108	C10208-4	100.UF 25V 20% RAD ELECT T/R	D 4
C109	C10208-4	100.UF 25V 20% RAD ELECT T/R	C 4
C110	C10466-8	.22UF 50V 5% MTL FILM RDL T/A	C 3
C111	C 8897-8	.1UF 100V 20% Z5U RAD CER T/R	H 3
C112	C 8897-8	.1UF 100V 20% Z5U RAD CER T/R	H 3
C113	C10599-6	.0047UF 50V 5% AXIAL CER T/R	C 3
C114	C10466-8	.22UF 50V 5% MTL FILM RDL T/A	C 1
C115	C10599-6	.0047UF 50V 5% AXIAL CER T/R	C 4
C116	C 8897-8	.1UF 100V 20% Z5U RAD CER T/R	C 1
C117	C 8897-8	.1UF 100V 20% Z5U RAD CER T/R	D 2
C118	C10466-8	.22UF 50V 5% MTL FILM RDL T/A	D 1
C119	C 8897-8	.1UF 100V 20% Z5U RAD CER T/R	D 3
C120	C 9161-8	.01 UF 50V 10% X7R RAD CER T/R	F 3
C121	C 8991-9	.47 UF 63V 5% FILM RAD T/A	D 2
C122	C 8897-8	.1UF 100V 20% Z5U RAD CER T/R	F 3
C123	C 8897-8	.1UF 100V 20% Z5U RAD CER T/R	F 3
C124	C10598-8	0.001, 100V, 5%, AX CERM	D 2
C125	C 9619-5	220PF 100V 5%AXIAL CER NPO T/R	D 2
C126	C 8897-8	.1UF 100V 20% Z5U RAD CER T/R	D 2
C127	C 8897-8	.1UF 100V 20% Z5U RAD CER T/R	C 2
C128	C 9619-5	220PF 100V 5%AXIAL CER NPO T/R	C 2
C129	C10598-8	0.001, 100V, 5%, AX CERM	C 2
C130	C10598-8	0.001, 100V, 5%, AX CERM	C 2
C131	C 9619-5	220PF 100V 5%AXIAL CER NPO T/R	C 3
C132	C10598-8	0.001, 100V, 5%, AX CERM	C 3
C133	C 8897-8	.1UF 100V 20% Z5U RAD CER T/R	C 5
C134	C 8897-8	.1UF 100V 20% Z5U RAD CER T/R	H 5
C135	C 9161-8	.01 UF 50V 10% X7R RAD CER T/R	D 5
C136	C 6807-9	.001UF 100V 10% AX CER T/R	C 2
C200	C 9161-8	.01 UF 50V 10% X7R RAD CER T/R	B 5
C201	101323-1	22PF 50V 10% N220 DISC T/R	B 4
C202	101323-1	22PF 50V 10% N220 DISC T/R	B 4
C203	C 5362-6	2.2UF 50V VERT ELECT T/A	G 5

**CROWN INTERNATIONAL INC.**

1718 WEST MISHAWAKA ROAD ELKHART, INDIANA 46517 PHONE (219) 294-8000

THESE DRAWINGS AND SPECIFICATIONS ARE THE PROPERTY OF CROWN INTERNATIONAL, INC. AND SHALL NOT BE REPRODUCED, COPIED, OR USED AS THE BASIS FOR THE MANUFACTURE OR SALE OF APPARATUS OR DEVICES WITHOUT PERMISSION.

DRAWN	JAW	03-17-99	DWG. NO.	SHEET 5 OF 12	REV
PROJ.	MD350D0		100524-6		(A)

PARTS LIST			
REF DES	C. P. N.	DESCRIPTION	MAP LOC.
C204	C 6802-0	.47UF 50V AXIAL CER T/R 474	G 5
C205	C 9161-8	.01 UF 50V 10% X7R RAD CER T/R	E 4
C206	C 9465-3	10UF 50V 20% VERT ELECT T/A	B 3
C207	101323-1	22PF 50V 10% N220 DISC T/R	B 4
C208	C10208-4	100.UF 25V 20% RAD ELECT T/R	B 4
C209	C10208-4	100.UF 25V 20% RAD ELECT T/R	A 4
C210	C10466-8	.22UF 50V 5% MTL FILM RDL T/A	B 3
C211	C 8897-8	.1UF 100V 20% Z5U RAD CER T/R	G 3
C212	C 8897-8	.1UF 100V 20% Z5U RAD CER T/R	G 3
C213	C10599-6	.0047UF 50V 5% AXIAL CER T/R	A 3
C214	C10466-8	.22UF 50V 5% MTL FILM RDL T/A	A 1
C215	C10599-6	.0047UF 50V 5% AXIAL CER T/R	A 4
C216	C 8897-8	.1UF 100V 20% Z5U RAD CER T/R	A 1
C217	C 8897-8	.1UF 100V 20% Z5U RAD CER T/R	B 2
C218	C10466-8	.22UF 50V 5% MTL FILM RDL T/A	B 1
C219	C 8897-8	.1UF 100V 20% Z5U RAD CER T/R	B 3
C220	C 9161-8	.01 UF 50V 10% X7R RAD CER T/R	E 3
C221	C 8991-9	.47 UF 63V 5% FILM RAD T/A	B 2
C222	C 8897-8	.1UF 100V 20% Z5U RAD CER T/R	E 3
C223	C 8897-8	.1UF 100V 20% Z5U RAD CER T/R	E 3
C224	C10598-8	0.001, 100V, 5%, AX CERM	B 2
C225	C 9619-5	220PF 100V 5%AXIAL CER NPO T/R	B 2
C226	C 8897-8	.1UF 100V 20% Z5U RAD CER T/R	B 2
C227	C 8897-8	.1UF 100V 20% Z5U RAD CER T/R	A 2
C228	C 9619-5	220PF 100V 5%AXIAL CER NPO T/R	A 2
C229	C10598-8	0.001, 100V, 5%, AX CERM	A 2
C230	C10598-8	0.001, 100V, 5%, AX CERM	A 2
C231	C 9619-5	220PF 100V 5%AXIAL CER NPO T/R	A 3
C232	C10598-8	0.001, 100V, 5%, AX CERM	A 3
C233	C 8897-8	.1UF 100V 20% Z5U RAD CER T/R	A 5
C234	C 8897-8	.1UF 100V 20% Z5U RAD CER T/R	E 5
C235	C 9161-8	.01 UF 50V 10% X7R RAD CER T/R	A 5
C236	C 6807-9	.001UF 100V 10% AX CER T/R	A 2
D1	C 3181-2	DIODE, 1N4148 T/R	H 1
D2	C 3181-2	DIODE, 1N4148 T/R	H 3
D3	C 3181-2	DIODE, 1N4148 T/R	H 3
D4	C 3181-2	DIODE, 1N4148 T/R	H 3
D5	C 3181-2	DIODE, 1N4148 T/R	H 3
D6	C 3181-2	DIODE, 1N4148 T/R	G 1
D7	C 3181-2	DIODE, 1N4148 T/R	G 3
D8	C 3181-2	DIODE, 1N4148 T/R	G 2
D100	C 3181-2	DIODE, 1N4148 T/R	F 4
D101	C 3181-2	DIODE, 1N4148 T/R	F 3
D102	C 3181-2	DIODE, 1N4148 T/R	F 3
D103	C 9738-3	DIODE, BAT85 30V 200MA SCHOTTKY	H 4
D104	C 3181-2	DIODE, 1N4148 T/R	H 4
D105	C 3181-2	DIODE, 1N4148 T/R	F 3
D106	C 3181-2	DIODE, 1N4148 T/R	F 2

**CROWN INTERNATIONAL INC.**

1718 WEST MISHAWAKA ROAD ELKHART, INDIANA 46517 PHONE (219) 294-8000

THESE DRAWINGS AND SPECIFICATIONS ARE THE PROPERTY OF CROWN INTERNATIONAL, INC. AND SHALL NOT BE REPRODUCED, COPIED, OR USED AS THE BASIS FOR THE MANUFACTURE OR SALE OF APPARATUS OR DEVICES WITHOUT PERMISSION.

DRAWN	JAW	03-17-99	DWG. NO.	SHEET 6 OF 12	REV
PROJ.	MD35000		100524-6		(A)

PARTS LIST			
REF DES	C. P. N.	DESCRIPTION	MAP LOC.
D107	C 3181-2	DIODE, 1N4148 T/R	F 1
D108	C 3181-2	DIODE, 1N4148 T/R	H 1
D109	C 3181-2	DIODE, 1N4148 T/R	H 4
D200	C 3181-2	DIODE, 1N4148 T/R	E 4
D201	C 3181-2	DIODE, 1N4148 T/R	E 3
D202	C 3181-2	DIODE, 1N4148 T/R	E 3
D203	C 9738-3	DIODE, BAT85 30V 200MA SCHOTTKY	G 4
D204	C 3181-2	DIODE, 1N4148 T/R	G 4
D205	C 3181-2	DIODE, 1N4148 T/R	E 3
D206	C 3181-2	DIODE, 1N4148 T/R	E 2
D207	C 3181-2	DIODE, 1N4148 T/R	E 1
D208	C 3181-2	DIODE, 1N4148 T/R	H 1
D209	C 3181-2	DIODE, 1N4148 T/R	H 4
J100	C10569-9	XLR, FEM HORZ PC MNT PLASTIC	E 5
J101	C10226-6	JK, 1/4" PHONE STEREO PC MNT	F 5
J102	C10612-7	PC MOUNT SCREW TERMINAL	H 5
J200	C10569-9	XLR, FEM HORZ PC MNT PLASTIC	C 5
J201	C10226-6	JK, 1/4" PHONE STEREO PC MNT	A 5
J202	C10612-7	PC MOUNT SCREW TERMINAL	A 5
P1	C10235-7	20 PIN HDR PICOFLEX GOLD	C 1
P2	C10514-5	26 PIN HDR PICOFLEX TIN	E 1
Q1	C 7458-0	2N4123 30V NPN T/R	H 2
Q2	C 3625-8	2N4125 30V PNP T/R	G 2
Q3	C 7458-0	2N4123 30V NPN T/R	G 3
Q100	C 7458-0	2N4123 30V NPN T/R	G 5
Q101	C 7458-0	2N4123 30V NPN T/R	F 4
Q102	C 3625-8	2N4125 30V PNP T/R	H 3
Q103	C 3625-8	2N4125 30V PNP T/R	F 2
Q200	C 7458-0	2N4123 30V NPN T/R	G 5
Q201	C 7458-0	2N4123 30V NPN T/R	E 4
Q202	C 3625-8	2N4125 30V PNP T/R	G 3
Q203	C 3625-8	2N4125 30V PNP T/R	E 2
R2	A10265-10021	10. KOHM .25W 1 MF T/R	C 4
R3	A10265-10021	10. KOHM .25W 1 MF T/R	C 4
R4	A10266-2221	2.2 KOHM .25W 5% CF T/R	F 2
R5	A10265-14031	140K .25W 1% MF T/R	E 2
R6	A10265-25511	2.55KOHM .25W 1 MF T/R	F 4
R7	A10265-14031	140K .25W 1% MF T/R	F 3
R8	A10266-1321	1.3 KOHM .25W 5 CF T/R	H 2
R9	A10266-1531	15. KOHM .25W 5% CF T/R	H 1
R10	A10265-15011	1.5 KOHM .25W 1% MF T/R	H 1
R11	A10266-2031	20. KOHM .25W 5 CF T/R	H 4
R12	A10266-1531	15. KOHM .25W 5% CF T/R	H 4
R13	A10266-2411	240 OHM .25W 5% CF T/R	G 4
R14	A10266-2221	2.2 KOHM .25W 5% CF T/R	H 3
R15	A10266-8231	82. KOHM .25W 5% CF T/R	G 1
R16	A10266-1011	100. OHM .25W 5% CF T/R	G 1
R17	A10266-1011	100. OHM .25W 5% CF T/R	G 2

**CROWN INTERNATIONAL INC.**

1718 WEST MISHAWAKA ROAD ELKHART, INDIANA 46517 PHONE (219) 294-8000

THESE DRAWINGS AND SPECIFICATIONS ARE THE PROPERTY OF CROWN INTERNATIONAL, INC. AND SHALL NOT BE REPRODUCED, COPIED, OR USED AS THE BASIS FOR THE MANUFACTURE OR SALE OF APPARATUS OR DEVICES WITHOUT PERMISSION.

DRAWN	JAW	03-17-99	DWG. NO.	SHEET 7 OF 12	REV
PROJ.	MD350D0		100524-6		(A)



PARTS LIST			
REF DES	C. P. N.	DESCRIPTION	MAP LOC.
R18	A10266-1031	10. KOHM .25W 5% CF T/R	G 2
R19	A10266-1041	100. KOHM .25W 5% CF25 T/R	G 2
R20	A10266-1031	10. KOHM .25W 5% CF T/R	G 3
R21		--- NOT USED ---	G 4
R22	A10266-1051	1. MOHM .25W 5% CF T/R	H 4
R23	A10266-2221	2.2 KOHM .25W 5% CF T/R	H 4
R24	A10266-1531	15 KOHM .25W 5% CF T/R	H 4
R100	C 7340-0	24.0 OHM 3W 5% MF FP T/R	C 4
R101		--- NOT USED ---	D 5
R102	A10265-49911	4.99KOHM .25W 1 MF T/R	D 4
R103	A10265-49911	4.99KOHM .25W 1 MF T/R	D 4
R104	A10265-49911	4.99KOHM .25W 1 MF T/R	D 4
R105	A10265-49911	4.99KOHM .25W 1 MF T/R	D 4
R106	A10265-10021	10. KOHM .25W 1 MF T/R	D 4
R107	A10265-10021	10. KOHM .25W 1 MF T/R	D 4
R108	A10266-5131	51. KOHM .25W 5 CF25 T/R	F 4
R109	A10266-3031	30. KOHM .25W 5 CF T/R	F 4
R110	A10266-3341	330. KOHM .25W 5% CF T/R	H 5
R112	A10266-2411	240 OHM .25W 5% CF T/R	H 5
R113	A10266-3941	390.KOHM .25W 5 CF T/R	F 4
R114	A10266-9131	91. KOHM .25W 5 CF T/R	F 4
R116	A10266-1021	1.0 KOHM .25W 5% CF T/R	F 4
R117	A10266-3941	390. KOHM .25W 1 MF T/R	F 2
R118	A10265-14031	140K .25W 1% MF T/R	F 3
R119	A10265-14031	140K .25W 1% MF T/R	F 3
R120	A10265-10031	100. KOHM .25W 1 MF T/R	F 3
R121	A10266-1511	150. OHM .25W 5 CF T/R	F 4
R122	A10265-10031	100. KOHM .25W 1 MF T/R	F 3
R123	A10266-2032	20. KOHM .5W 5 CF T/R	H 4
R124	A10266-2041	200. KOHM .25W 5 CF T/R	H 3
R125	A10266-1551	1.5 MOHM .25W 5% CF T/R	H 3
R126	A10265-88711	8.87KOHM .25W 1% MF T/R	D 3
R127	A10265-15821	15.8KOHM .25W 1% MF T/R	D 3
R128	A10266-8211	820. OHM .25W 5% CF T/R	H 3
R129	A10266-2211	220. OHM .25W 5 CF T/R	H 3
R130	A10265-20021	20. KOHM .25W 1 MF T/R	D 4
R131	A10266-3921	3.9 KOHM .25W 5% CF T/R	C 3
R133	A10266-2211	220. OHM .25W 5 CF T/R	F 2
R134	A10265-10531	105KOHM .25W 1% MF T/R	C 3
R135	A10266-1531	15. KOHM .25W 5% CF T/R	F 2
R136	A10265-19111	1.91KOHM .25W 1 MF T/R	C 4
R137	A10265-10731	107.KOHM .25W 1% MF T/R	C 2
R138	A10265-19111	1.91KOHM .25W 1 MF T/R	C 3
R139	A10266-1031	10. KOHM .25W 5% CF T/R	C 2
R140	A10266-1051	1. MOHM .25W 5% CF T/R	C 1
R141	A10265-68131	681KOHM .25W 1% MF T/R	D 1
R142	A10266-4751	4.7 MOHM .25W 5 CF T/R	H 2
R143	A10265-10031	100. KOHM .25W 1 MF T/R	D 3
R144	A10266-3941	390.KOHM .25W 5 CF T/R	H 2
R145	A10265-49931	499KOHM .25W 1% MF T/R	F 2

**CROWN INTERNATIONAL INC.**

1718 WEST MISHAWAKA ROAD ELKHART, INDIANA 46517 PHONE (219) 294-8000

THESE DRAWINGS AND SPECIFICATIONS ARE THE PROPERTY OF CROWN INTERNATIONAL, INC. AND SHALL NOT BE REPRODUCED, COPIED, OR USED AS THE BASIS FOR THE MANUFACTURE OR SALE OF APPARATUS OR DEVICES WITHOUT PERMISSION.

DRAWN	JAW	03-17-99	DWG. NO.	SHEET 8 OF 12	REV
PROJ.	MD350D0		100524-6		(A)

PARTS LIST			
REF DES	C. P. N.	DESCRIPTION	MAP LOC.
R146	A10266-2741	270. KOHM .25W 5% CF25 T/R	F 3
R147	A10265-49931	499KOHM .25W 1% MF T/R	F 1
R148	A10265-49931	499KOHM .25W 1% MF T/R	D 2
R149	A10266-4751	4.7 MOHM .25W 5 CF T/R	C 1
R150	A10266-3951	3.9 MOHM .25W 5% CF T/R	H 2
R151	A10266-1321	1.3 KOHM .25W 5% CF T/R	D 3
R152	A10266-2421	2.4 KOHM .25W 5% CF T/R	D 3
R153	A10265-49931	499KOHM .25W 1% MF T/R	F 2
R154	A10266-2041	200. KOHM .25W 5 CF T/R	H 2
R155	A10266-1031	10. KOHM .25W 5% CF T/R	H 3
R156	A10265-15011	1.5 KOHM .25W 1% MF T/R	D 3
R157	A10266-4712	470. OHM .5W 5% CF T/R	F 1
R162	A10265-16221	16.2 KOHM .25W 1 MF T/R	D 2
R163	A10265-49931	499KOHM .25W 1% MF T/R	F 2
R164	A10265-10031	100. KOHM .25W 1 MF T/R	F 2
R165	A10265-49921	49.9 KOHM .25W 1 MF T/R	F 1
R166	A10265-20031	200. KOHM .25W 1 MF T/R	F 2
R167	A10265-22111	2.21KOHM .25W 1% MF T/R	D 2
R168	A10265-02511	0.25KOHM .25W 1% MF T/R	C 2
R169	A10265-42211	4.22KOHM .25W 1% MF T/R	C 2
R170	A10265-25511	2.55KOHM .25W 1 MF T/R	C 2
R171	A10265-60411	6.04KOHM .25W 1 MF T/R	C 3
R172	C10613-5	1 KOHM TOP ADJUST TRIMMER T/R	C 3
R200	C 7340-0	24.0 OHM 3W 5% MF FP T/R	A 4
R201		--- NOT USED ---, . .	C 5
R202	A10265-49911	4.99KOHM .25W 1 MF T/R	B 4
R203	A10265-49911	4.99KOHM .25W 1 MF T/R	B 4
R204	A10265-49911	4.99KOHM .25W 1 MF T/R	B 4
R205	A10265-49911	4.99KOHM .25W 1 MF T/R	B 4
R206	A10265-10021	10. KOHM .25W 1 MF T/R	B 4
R207	A10265-10021	10. KOHM .25W 1 MF T/R	B 4
R208	A10266-5131	51. KOHM .25W 5 CF25 T/R	F 4
R209	A10266-3031	30. KOHM .25W 5 CF T/R	E 4
R210	A10266-3341	330. KOHM .25W 5% CF T/R	G 5
R212	A10266-2411	240 OHM .25W 5% CF T/R	G 5
R213	A10266-3941	390. KOHM .25W 5 CF T/R	E 4
R214	A10266-9131	91. KOHM .25W 5 CF T/R	E 4
R216	A10266-1021	1.0 KOHM .25W 5% CF T/R	E 4
R217	A10266-3941	390. KOHM .25W 1 MF T/R	E 2
R218	A10265-14031	140K .25W 1% MF T/R	E 3
R219	A10265-14031	140K .25W 1% MF T/R	E 3
R220	A10265-10031	100. KOHM .25W 1 MF T/R	E 3
R221	A10266-1511	150. OHM .25W 5 CF T/R	E 4
R222	A10265-10031	100. KOHM .25W 1 MF T/R	E 3
R223	A10266-2032	20. KOHM .5W 5 CF T/R	G 4
R224	A10266-2041	200. KOHM .25W 5 CF T/R	G 4
R225	A10266-1551	1.5 MOHM .25W 5% CF T/R	G 3

**CROWN INTERNATIONAL INC.**

1718 WEST MISHAWAKA ROAD ELKHART, INDIANA 46517 PHONE (219) 294-8000

THESE DRAWINGS AND SPECIFICATIONS ARE THE PROPERTY OF CROWN INTERNATIONAL, INC. AND SHALL NOT BE REPRODUCED, COPIED, OR USED AS THE BASIS FOR THE MANUFACTURE OR SALE OF APPARATUS OR DEVICES WITHOUT PERMISSION.

DRAWN	JAW	03-17-99	DWG. NO.	SHEET 9 OF 12	REV
PROJ.	MD35000		100524-6		(A)

PARTS LIST			
REF DES	C.P.N.	DESCRIPTION	MAP LOC.
R226	A10265-88711	8.87KOHM .25W 1% MF T/R	B 3
R227	A10265-15821	15.8KOHM .25W 1% MF T/R	B 3
R228	A10266-8211	820. OHM .25W 5% CF T/R	G 3
R229	A10266-2211	220. OHM .25W 5 CF T/R	G 3
R230	A10265-20021	20. KOHM .25W 1 MF T/R	B 4
R231	A10266-3921	3.9 KOHM .25W 5% CF T/R	A 3
R233	A10266-2211	220. OHM .25W 5 CF T/R	E 2
R234	A10265-10531	105KOHM .25W 1% MF T/R	A 3
R235	A10266-1531	15. KOHM .25W 5% CF T/R	E 2
R236	A10265-19111	1.91KOHM .25W 1 MF T/R	A 4
R237	A10265-10731	107.KOHM .25W 1% MF T/R	A 2
R238	A10265-19111	1.91KOHM .25W 1 MF T/R	A 3
R239	A10266-1031	10. KOHM .25W 5% CF T/R	A 2
R240	A10266-1051	1. MOHM .25W 5% CF T/R	A 1
R241	A10265-68131	681KOHM .25W 1% MF T/R	B 1
R242	A10266-4751	4.7 MOHM .25W 5 CF T/R	H 2
R243	A10265-10031	100. KOHM .25W 1 MF T/R	B 3
R244	A10266-3941	390.KOHM .25W 5 CF T/R	H 2
R245	A10265-49931	499KOHM .25W 1% MF T/R	E 2
R246	A10266-2741	270. KOHM .25W 5% CF25 T/R	E 3
R247	A10265-49931	499KOHM .25W 1% MF T/R	B 1
R248	A10265-49931	499KOHM .25W 1% MF T/R	B 2
R249	A10266-4751	4.7 MOHM .25W 5 CF T/R	A 1
R250	A10266-3951	3.9 MOHM .25W 5% CF T/R	H 2
R251	A10266-1321	1.3 KOHM .25W 5% CF T/R	B 3
R252	A10266-2421	2.4 KOHM .25W 5% CF T/R	B 3
R253	A10265-49931	499KOHM .25W 1% MF T/R	E 2
R254	A10266-2041	200. KOHM .25W 5 CF T/R	H 2
R255	A10266-1031	10. KOHM .25W 5% CF T/R	H 2
R256	A10265-15011	1.5 KOHM .25W 1% MF T/R	B 3
R257	A10266-4712	470. OHM .5W 5% CF T/R	E 1
R262	A10265-16221	16.2 KOHM .25W 1 MF T/R	B 2
R263	A10265-49931	499KOHM .25W 1% MF T/R	E 2
R264	A10265-10031	100. KOHM .25W 1 MF T/R	E 2
R265	A10265-49921	49.9 KOHM .25W 1 MF T/R	E 1
R266	A10265-20031	200.KOHM .25W 1 MF T/R	E 2
R267	A10265-22111	2.21KOHM .25W 1% MF T/R	B 2
R268	A10265-82511	8.25KOHM .25W 1% MF T/R	A 2
R269	A10265-42211	4.22KOHM .25W 1% MF T/R	A 2
R270	A10265-25511	2.55KOHM .25W 1 MF T/R	A 2
R271	A10265-60411	6.04KOHM .25W 1 MF T/R	A 3
R272	C10613-5	1 KOHM TOP ADJUST TRIMMER T/R	B 3
S1	C 7325-1	2POLE 2POS PC SLIDE SWITCH	D 5
S2	C 7325-1	2POLE 2POS PC SLIDE SWITCH	D 5
S3		--- NOT USED ---	G 5
S100	C 7325-1	2POLE 2POS PC SLIDE SWITCH	F 5
S200	C 7325-1	2POLE 2POS PC SLIDE SWITCH	B 5

<b>CROWN INTERNATIONAL INC.</b>			
1718 WEST MISHAWAKA ROAD		ELKHART, INDIANA 46517	PHONE (219) 294-8000
DRAWN	JAW	03-17-99	DWG. NO.
PROJ.	MD350D0	100524-6	
			SHEET 10 OF 12
			REV (A)

THESE DRAWINGS AND SPECIFICATIONS ARE THE PROPERTY OF CROWN INTERNATIONAL, INC. AND SHALL NOT BE REPRODUCED, COPIED, OR USED AS THE BASIS FOR THE MANUFACTURE OR SALE OF APPARATUS OR DEVICES WITHOUT PERMISSION.

PARTS LIST			
REF DES	C. P. N.	DESCRIPTION	MAP LOC.
U1	C10536-8	OP AMP, LM324AN	F 4
U2	C 4345-2	LM339N VOLT COMPARATOR	H 3
U3	C10536-8	OP AMP, LM324AN	F 1
U4	C 4345-2	LM339N VOLT COMPARATOR	E 1
U5	C 4345-2	LM339N VOLT COMPARATOR	H 2
U100	102723-1	OPTO-CELL ON=500 OHM	D 5
U101	C 7558-7	MC33079P QUAD LOW NOISE OP AMP	D 4
U102	C 4345-2	LM339N VOLT COMPARATOR	F 3
U103	C 7558-7	MC33079P QUAD LOW NOISE OP AMP	D 2
U105	C10535-0	OP AMP, MC3476P1	D 1
U200	102723-1	OPTO-CELL ON=500 OHM	B 5
U201	C 7558-7	MC33079P QUAD LOW NOISE OP AMP	B 4
U202	C 4345-2	LM339N VOLT COMPARATOR	E 3
U203	C 7558-7	MC33079P QUAD LOW NOISE OP AMP	B 2
U205	C10535-0	OP AMP, MC3476P1	B 1
Z1		--- NOT USED ---, . .	G 2
	101016-1	LBL, BARCODE	H 1

<b>CROWN INTERNATIONAL INC.</b>			
1718 WEST MISHAWAKA ROAD		ELKHART, INDIANA 46517	
PHONE (219) 294-8000			
<b>DRAWN</b>	<b>JAW</b>	<b>03-17-99</b>	<b>DWG. NO.</b>
		100524-6	
<b>PROJ.</b>	<b>MD35008</b>	<b>SHEET 11 OF 12</b>	<b>REV</b>
			ⓐ

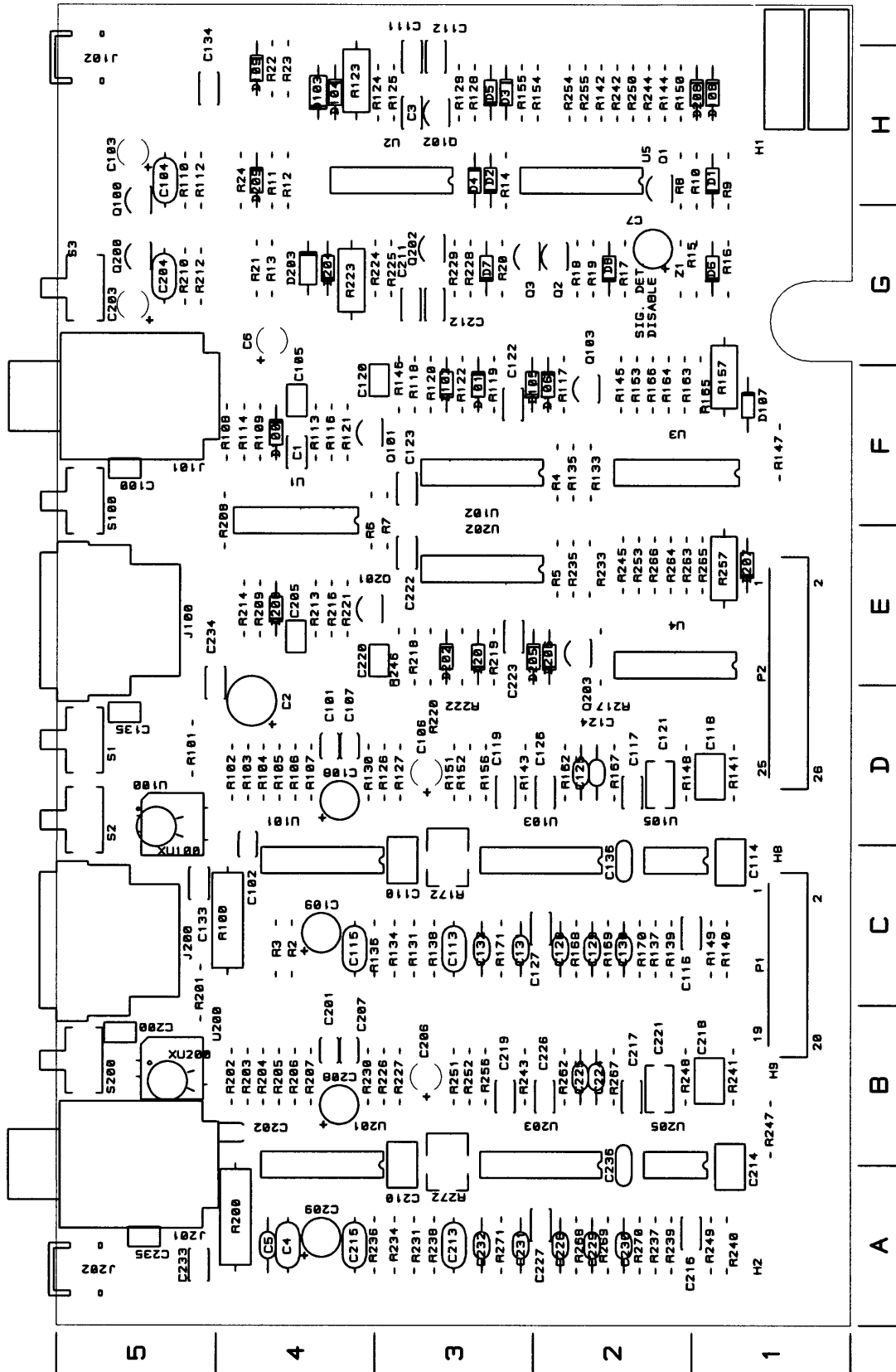

100524-6 PWA Component Map (Component Side)

**NOTES:**

1. SCHEMATIC DRAWING NUMBER 101012.
2. PRINTED WIRING BOARD PART NUMBER 101013-2.
3. PRINTED WIRING ASSEMBLY PART NUMBER 101014-2.

THESE DRAWINGS AND SPECIFICATIONS ARE THE PROPERTY OF CROWN INTERNATIONAL, INC. AND SHALL NOT BE REPRODUCED, COPIED, OR USED AS THE BASIS FOR THE MANUFACTURE OR SALE OF APPARATUS OR DEVICES WITHOUT PERMISSION.

<b>CROWN INTERNATIONAL INC.</b>				
1718 WEST MISHAWAKA ROAD		ELKHART, INDIANA 48517		PHONE (219) 294-8000
<b>DRAWN</b>	KLW	11-11-96	<b>DWG. NO.</b>	SHEET 3
<b>PROJ.</b>	D350		101014	CONT. ON SHEET 4
				<b>REV</b> Ⓟ



### COMPONENT MAP (COMPONENT SIDE VIEW)

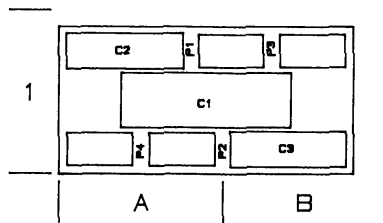

CROWN INTERNATIONAL INC.

1718 WEST MISHAWAKA RD. ELKHART, INDIANA 46517 PHONE (219)294-8000

THESE DRAWINGS AND SPECIFICATIONS ARE THE PROPERTY OF CROWN INTERNATIONAL, INC. AND SHALL NOT BE REPRODUCED, COPIED, OR USED AS THE BASIS FOR THE MANUFACTURE OR SALE OF APPARATUS OR DEVICES WITHOUT PERMISSION.

DRAWN	KLW	10-18-98	DWG. NO.	101014	SHEET 6	REV
PROJ.	D350					(A)



E.C.	ZONE	REV.	DESCRIPTION	DATE	BY	APPROVALS			
						CHK	CM	EE	PE
		A	INITIAL RELEASE FOR PRODUCTION (LEVEL I)	03-17-99	JAW	JM		ER	ER

NOTES:

1. SCHEMATIC DRAWING NUMBER 101946.
2. PRINTED WIRING BOARD PART NUMBER 100523-7.



CAUTION

STATIC CAN DAMAGE COMPONENTS!

DO NOT HANDLE

UNLESS WRIST STRAP IS WORN

THESE DRAWINGS AND SPECIFICATIONS ARE THE PROPERTY OF CROWN INTERNATIONAL, INC. AND SHALL NOT BE REPRODUCED, COPIED, OR USED AS THE BASIS FOR THE MANUFACTURE OR SALE OF APPARATUS OR DEVICES WITHOUT PERMISSION.

<b>PRINTS TO</b>		<b>CROWN INTERNATIONAL INC.</b>					
K		1718 WEST MISHAWAKA ROAD ELKHART, INDIANA 46517				PHONE (219) 294-8000	
		PWA, INPUT K1				TOL. UNLESS SPECIFIED X.XX = ± 0.020 X.XXX = ± 0.010 DRILLS = ± 0.003	
		DRAWN	JAW	03-17-99	APPROVED BY:	DO NOT SCALE PRINT	
		CHECKED	JM	3-18-99	ME JW	SUPERSEDES	
		SCALE	NONE		EE	E.C.N.	
		PROJ	MD350D0		PE	C.P.N. SHEET 1 OF 12	
		FILENAME: 101809-4_A_01.PCB				101809-4	REV A

PARTS LIST			
REF DES	C. P. N.	DESCRIPTION	MAP LOC.
C1	C 8897-8	.1UF 100V 20% Z5U RAD CER T/R	F 4
C2	C10516-0	470.UF 10V 20% LOW ESR RDL T/R	D 4
C3	C 8897-8	.1UF 100V 20% Z5U RAD CER T/R	H 3
C4	C 6802-0	.47UF 50V AXIAL CER T/R 474	A 4
C5	C 9620-3	47PF 200V 5% AXIAL CER NPO T/R	A 4
C6	C 5362-6	2.2UF 50V VERT ELECT T/A	G 4
C7	C10208-4	100.UF 25V 20% RAD ELECT T/R	G 2
C100	C 9161-8	.01 UF 50V 10% X7R RAD CER T/R	F 5
C101	101323-1	22PF 50V 10% N220 DISC T/R	D 4
C102	101323-1	22PF 50V 10% N220 DISC T/R	D 4
C103		--- NOT USED ---	H 5
C104	C 6802-0	.47UF 50V AXIAL CER T/R 474	H 5
C105	A10266-1641	160 KOHM .25W 5% CF T/R	F 4
C106	C 9465-3	10UF 50V 20% VERT ELECT T/A	D 3
C107	101323-1	22PF 50V 10% N220 DISC T/R	D 4
C108	C10208-4	100.UF 25V 20% RAD ELECT T/R	D 4
C109	C10208-4	100.UF 25V 20% RAD ELECT T/R	C 4
C110	C10466-8	.22UF 50V 5% MTL FILM RDL T/A	C 3
C111	C 8897-8	.1UF 100V 20% Z5U RAD CER T/R	H 3
C112	C 8897-8	.1UF 100V 20% Z5U RAD CER T/R	H 3
C113	C10599-6	.0047UF 50V 5% AXIAL CER T/R	C 3
C114	C10466-8	.22UF 50V 5% MTL FILM RDL T/A	C 1
C115	C10599-6	.0047UF 50V 5% AXIAL CER T/R	C 4
C116	C 8897-8	.1UF 100V 20% Z5U RAD CER T/R	C 1
C117	C 8897-8	.1UF 100V 20% Z5U RAD CER T/R	D 2
C118	C10466-8	.22UF 50V 5% MTL FILM RDL T/A	D 1
C119	C 8897-8	.1UF 100V 20% Z5U RAD CER T/R	D 3
C120	C 9161-8	.01 UF 50V 10% X7R RAD CER T/R	F 3
C121	C 8991-9	.47 UF 63V 5% FILM RAD T/A	D 2
C122	C 8897-8	.1UF 100V 20% Z5U RAD CER T/R	F 3
C123	C 8897-8	.1UF 100V 20% Z5U RAD CER T/R	F 3
C124	C10598-8	0.001, 100V, 5%, AX CERM	D 2
C125	C 9619-5	220PF 100V 5%AXIAL CER NPO T/R	D 2
C126	C 8897-8	.1UF 100V 20% Z5U RAD CER T/R	D 2
C127	C 8897-8	.1UF 100V 20% Z5U RAD CER T/R	C 2
C128	C 9619-5	220PF 100V 5%AXIAL CER NPO T/R	C 2
C129	C10598-8	0.001, 100V, 5%, AX CERM	C 2
C130	C10598-8	0.001, 100V, 5%, AX CERM	C 2
C131	C 9619-5	220PF 100V 5%AXIAL CER NPO T/R	C 3
C132	C10598-8	0.001, 100V, 5%, AX CERM	C 3
C133	C 8897-8	.1UF 100V 20% Z5U RAD CER T/R	C 5
C134	C 8897-8	.1UF 100V 20% Z5U RAD CER T/R	H 5
C135	C 9161-8	.01 UF 50V 10% X7R RAD CER T/R	D 5
C136	C 6807-9	.001UF 100V 10% AX CER T/R	C 2
C200	C 9161-8	.01 UF 50V 10% X7R RAD CER T/R	B 5
C201	101323-1	22PF 50V 10% N220 DISC T/R	B 4
C202	101323-1	22PF 50V 10% N220 DISC T/R	B 4
C203		--- NOT USED ---	G 5

**CROWN INTERNATIONAL INC.**

1718 WEST MISHAWAKA ROAD ELKHART, INDIANA 46517 PHONE (219) 294-8000

THESE DRAWINGS AND SPECIFICATIONS ARE THE PROPERTY OF CROWN INTERNATIONAL, INC. AND SHALL NOT BE REPRODUCED, COPIED, OR USED AS THE BASIS FOR THE MANUFACTURE OR SALE OF APPARATUS OR DEVICES WITHOUT PERMISSION.

DRAWN	JAW	03-17-99	DWG. NO.	SHEET 5 OF 12	REV
PROJ.	MD350D0		101809-4		(A)

PARTS LIST			
REF DES	C. P. N.	DESCRIPTION	MAP LOC.
C204	C 6802-0	.47UF 50V AXIAL CER T/R 474	G 5
C205	A10266-1641	160 KOHM .25W 5% CF T/R	E 4
C206	C 9465-3	10UF 50V 20% VERT ELECT T/A	B 3
C207	101323-1	22PF 50V 10% N220 DISC T/R	B 4
C208	C10208-4	100.UF 25V 20% RAD ELECT T/R	B 4
C209	C10208-4	100.UF 25V 20% RAD ELECT T/R	A 4
C210	C10466-8	.22UF 50V 5% MTL FILM RDL T/A	B 3
C211	C 8897-8	.1UF 100V 20% Z5U RAD CER T/R	G 3
C212	C 8897-8	.1UF 100V 20% Z5U RAD CER T/R	G 3
C213	C10599-6	.0047UF 50V 5% AXIAL CER T/R	A 3
C214	C10466-8	.22UF 50V 5% MTL FILM RDL T/A	A 1
C215	C10599-6	.0047UF 50V 5% AXIAL CER T/R	A 4
C216	C 8897-8	.1UF 100V 20% Z5U RAD CER T/R	A 1
C217	C 8897-8	.1UF 100V 20% Z5U RAD CER T/R	B 2
C218	C10466-8	.22UF 50V 5% MTL FILM RDL T/A	B 1
C219	C 8897-8	.1UF 100V 20% Z5U RAD CER T/R	B 3
C220	C 9161-8	.01 UF 50V 10% X7R RAD CER T/R	E 3
C221	C 8991-9	.47 UF 63V 5% FILM RAD T/A	B 2
C222	C 8897-8	.1UF 100V 20% Z5U RAD CER T/R	E 3
C223	C 8897-8	.1UF 100V 20% Z5U RAD CER T/R	E 3
C224	C10598-8	0.001, 100V, 5%, AX CERM	B 2
C225	C 9619-5	220PF 100V 5%AXIAL CER NPO T/R	B 2
C226	C 8897-8	.1UF 100V 20% Z5U RAD CER T/R	B 2
C227	C 8897-8	.1UF 100V 20% Z5U RAD CER T/R	A 2
C228	C 9619-5	220PF 100V 5%AXIAL CER NPO T/R	A 2
C229	C10598-8	0.001, 100V, 5%, AX CERM	A 2
C230	C10598-8	0.001, 100V, 5%, AX CERM	A 2
C231	C 9619-5	220PF 100V 5%AXIAL CER NPO T/R	A 3
C232	C10598-8	0.001, 100V, 5%, AX CERM	A 3
C233	C 8897-8	.1UF 100V 20% Z5U RAD CER T/R	A 5
C234	C 8897-8	.1UF 100V 20% Z5U RAD CER T/R	E 5
C235	C 9161-8	.01 UF 50V 10% X7R RAD CER T/R	A 5
C236	C 6807-9	.001UF 100V 10% AX CER T/R	A 2
D1	C 3181-2	DIODE, 1N4148 T/R	H 1
D2	C 3181-2	DIODE, 1N4148 T/R	H 3
D3	C 3181-2	DIODE, 1N4148 T/R	H 3
D4	C 3181-2	DIODE, 1N4148 T/R	H 3
D5	C 3181-2	DIODE, 1N4148 T/R	H 3
D6	C 3181-2	DIODE, 1N4148 T/R	G 1
D7	C 3181-2	DIODE, 1N4148 T/R	G 3
D8	C 3181-2	DIODE, 1N4148 T/R	G 2
D100		--- NOT USED ---	F 4
D101	C 3181-2	DIODE, 1N4148 T/R	F 3
D102	C 3181-2	DIODE, 1N4148 T/R	F 3
D103	C 9738-3	DIODE, BAT85 30V 200MA SCHOTTKY	H 4
D104	C 3181-2	DIODE, 1N4148 T/R	H 4
D105	C 3181-2	DIODE, 1N4148 T/R	F 3
D106	C 3181-2	DIODE, 1N4148 T/R	F 2

<b>CROWN INTERNATIONAL INC.</b>			
1718 WEST MISHAWAKA ROAD ELKHART, INDIANA 46517 PHONE (219) 294-8000			
THESE DRAWINGS AND SPECIFICATIONS ARE THE PROPERTY OF CROWN INTERNATIONAL, INC. AND SHALL NOT BE REPRODUCED, COPIED, OR USED AS THE BASIS FOR THE MANUFACTURE OR SALE OF APPARATUS OR DEVICES WITHOUT PERMISSION.	DRAWN	JAW 03-17-99	DWG. NO.
	PROJ.	MD350D0	101809-4
		SHEET 6 OF 12	REV (A)

PARTS LIST			
REF DES	C.P.N.	DESCRIPTION	MAP LOC.
D107	C 3181-2	DIODE, 1N4148 T/R	F 1
D108	C 3181-2	DIODE, 1N4148 T/R	H 1
D109	C 3181-2	DIODE, 1N4148 T/R	H 4
D200		--- NOT USED ---	E 4
D201	C 3181-2	DIODE, 1N4148 T/R	E 3
D202	C 3181-2	DIODE, 1N4148 T/R	E 3
D203	C 9738-3	DIODE, BAT85 30V 200MA SCHOTTKY	G 4
D204	C 3181-2	DIODE, 1N4148 T/R	G 4
D205	C 3181-2	DIODE, 1N4148 T/R	E 3
D206	C 3181-2	DIODE, 1N4148 T/R	E 2
D207	C 3181-2	DIODE, 1N4148 T/R	E 1
D208	C 3181-2	DIODE, 1N4148 T/R	H 1
D209	C 3181-2	DIODE, 1N4148 T/R	H 4
J100	C10569-9	XLR, FEM HORZ PC MNT PLASTIC	E 5
J101	C10226-6	JK, 1/4" PHONE STEREO PC MNT	F 5
J102	C10612-7	PC MOUNT SCREW TERMINAL	H 5
J200	C10569-9	XLR, FEM HORZ PC MNT PLASTIC	C 5
J201	C10226-6	JK, 1/4" PHONE STEREO PC MNT	A 5
J202	C10612-7	PC MOUNT SCREW TERMINAL	A 5
P1	C10235-7	20 PIN HDR PICOFLEX GOLD	C 1
P2	C10514-5	26 PIN HDR PICOFLEX TIN	E 1
Q1	C 7458-0	2N4123 30V NPN T/R	H 2
Q2	C 3625-8	2N4125 30V PNP T/R	G 2
Q3	C 7458-0	2N4123 30V NPN T/R	G 3
Q100	C 7458-0	2N4123 30V NPN T/R	G 5
Q101	C 7458-0	2N4123 30V NPN T/R	F 4
Q102	C 3625-8	2N4125 30V PNP T/R	H 3
Q103	C 3625-8	2N4125 30V PNP T/R	F 2
Q200	C 7458-0	2N4123 30V NPN T/R	G 5
Q201	C 7458-0	2N4123 30V NPN T/R	E 4
Q202	C 3625-8	2N4125 30V PNP T/R	G 3
Q203	C 3625-8	2N4125 30V PNP T/R	E 2
R2	A10265-10021	10. KOHM .25W 1 MF T/R	C 4
R3	A10265-10021	10. KOHM .25W 1 MF T/R	C 4
R4	A10266-2221	2.2 KOHM .25W 5% CF T/R	F 2
R5	A10265-14031	140K .25W 1% MF T/R	E 2
R6	A10265-25511	2.55KOHM .25W 1 MF T/R	F 4
R7	A10265-14031	140K .25W 1% MF T/R	F 3
R8	A10266-1321	1.3 KOHM .25W 5 CF T/R	H 2
R9	A10266-1531	15. KOHM .25W 5% CF T/R	H 1
R10	A10265-15011	1.5 KOHM .25W 1% MF T/R	H 1
R11	A10266-2031	20. KOHM .25W 5 CF T/R	H 4
R12	A10266-1531	15. KOHM .25W 5% CF T/R	H 4
R13	A10266-2411	240 OHM .25W 5% CF T/R	G 4
R14	A10266-2221	2.2 KOHM .25W 5% CF T/R	H 3
R15	A10266-8231	82. KOHM .25W 5% CF T/R	G 1
R16	A10266-1011	100. OHM .25W 5% CF T/R	G 1
R17	A10266-1011	100. OHM .25W 5% CF T/R	G 2

**CROWN INTERNATIONAL INC.**

1718 WEST MISHAWAKA ROAD ELKHART, INDIANA 46517 PHONE (219) 294-8080

THESE DRAWINGS AND SPECIFICATIONS ARE THE PROPERTY OF CROWN INTERNATIONAL, INC. AND SHALL NOT BE REPRODUCED, COPIED, OR USED AS THE BASIS FOR THE MANUFACTURE OR SALE OF APPARATUS OR DEVICES WITHOUT PERMISSION.

DRAWN	JAW	03-17-99	DWG. NO.	101809-4	SHEET 7 OF 12	REV
PROJ.	MD350D0					(A)

PARTS LIST			
REF DES	C. P. N.	DESCRIPTION	MAP LOC.
R18	A10266-1031	10. KOHM .25W 5% CF T/R	G 2
R19	A10266-1041	100. KOHM .25W 5% CF25 T/R	G 2
R20	A10266-1031	10. KOHM .25W 5% CF T/R	G 3
R21		--- NOT USED ---	G 4
R22	A10266-1051	1. MOHM .25W 5% CF T/R	H 4
R23	A10266-2221	2.2 KOHM .25W 5% CF T/R	H 4
R24	A10266-1531	15 KOHM .25W 5% CF T/R	H 4
R100	C 7340-0	24.0 OHM 3W 5% MF FP T/R	C 4
R101		--- NOT USED ---	D 5
R102	A10265-49911	4.99KOHM .25W 1 MF T/R	D 4
R103	A10265-49911	4.99KOHM .25W 1 MF T/R	D 4
R104	A10265-49911	4.99KOHM .25W 1 MF T/R	D 4
R105	A10265-49911	4.99KOHM .25W 1 MF T/R	D 4
R106	A10265-10021	10. KOHM .25W 1 MF T/R	D 4
R107	A10265-10021	10. KOHM .25W 1 MF T/R	D 4
R108		--- NOT USED ---	F 4
R109	A10266-3031	30. KOHM .25W 5 CF T/R	F 4
R110	A10266-6841	680 KOHM .25W 5% CF T/R	H 5
R112	A10266-2411	240 OHM .25W 5% CF T/R	H 5
R113	A10266-3941	390.KOHM .25W 5 CF T/R	F 4
R114	A10266-9131	91. KOHM .25W 5 CF T/R	F 4
R116	A10266-1021	1.0 KOHM .25W 5% CF T/R	F 4
R117		--- NOT USED ---	F 2
R118	A10265-14031	140K .25W 1% MF T/R	F 3
R119	A10265-14031	140K .25W 1% MF T/R	F 3
R120	A10265-10031	100. KOHM .25W 1 MF T/R	F 3
R121	A10266-1511	150. OHM .25W 5 CF T/R	F 4
R122	A10265-10031	100. KOHM .25W 1 MF T/R	F 3
R123	A10266-2032	20. KOHM .5W 5 CF T/R	H 4
R124	A10266-2041	200. KOHM .25W 5 CF T/R	H 3
R125	A10266-1551	1.5 MOHM .25W 5% CF T/R	H 3
R126	A10265-88711	8.87KOHM .25W 1% MF T/R	D 3
R127	A10265-18721	18.7KOHM .25W 1% MF T/R	D 3
R128	A10266-8211	820. OHM .25W 5% CF T/R	H 3
R129	A10266-2211	220. OHM .25W 5 CF T/R	H 3
R130	A10265-16921	16.9 KOHM .25W 1 MF T/R	D 4
R131	A10266-3921	3.9 KOHM .25W 5% CF T/R	C 3
R133	A10266-2211	220. OHM .25W 5 CF T/R	F 2
R134	A10265-10531	105KOHM .25W 1% MF T/R	C 3
R135	A10266-1531	15. KOHM .25W 5% CF T/R	F 2
R136	A10265-19111	1.91KOHM .25W 1 MF T/R	C 4
R137	A10265-10731	107.KOHM .25W 1% MF T/R	C 2
R138	A10265-19111	1.91KOHM .25W 1 MF T/R	C 3
R139	A10266-1031	10. KOHM .25W 5% CF T/R	C 2
R140	A10266-1051	1. MOHM .25W 5% CF T/R	C 1
R141	A10265-68131	681KOHM .25W 1% MF T/R	D 1
R142	A10266-4751	4.7 MOHM .25W 5 CF T/R	H 2
R143	A10265-10031	100. KOHM .25W 1 MF T/R	D 3
R144	A10266-3941	390.KOHM .25W 5 CF T/R	H 2
R145	A10265-49931	499KOHM .25W 1% MF T/R	F 2

## CROWN INTERNATIONAL INC.

1718 WEST MISHAWAKA ROAD ELKHART, INDIANA 46517 PHONE (219) 294-8000

THESE DRAWINGS AND SPECIFICATIONS ARE THE PROPERTY OF CROWN INTERNATIONAL, INC. AND SHALL NOT BE REPRODUCED, COPIED, OR USED AS THE BASIS FOR THE MANUFACTURE OR SALE OF APPARATUS OR DEVICES WITHOUT PERMISSION.

DRAWN JAW 03-17-99

DWG. NO.

SHEET 8 OF 12

REV

PROJ.

MD35000

101809-4

A

PARTS LIST			
REF DES	C. P. N.	DESCRIPTION	MAP LOC.
R146	A10266-2741	270. KOHM .25W 5% CF25 T/R	F 3
R147	A10265-49931	499KOHM .25W 1% MF T/R	F 1
R148	A10265-49931	499KOHM .25W 1% MF T/R	D 2
R149	A10266-4751	4.7 MOHM .25W 5 CF T/R	C 1
R150	A10266-3951	3.9 MOHM .25W 5% CF T/R	H 2
R151	A10266-1321	1.3 KOHM .25W 5% CF T/R	D 3
R152	A10266-2421	2.4 KOHM .25W 5% CF T/R	D 3
R153	A10265-49931	499KOHM .25W 1% MF T/R	F 2
R154	A10266-2041	200. KOHM .25W 5 CF T/R	H 2
R155	A10266-1031	10. KOHM .25W 5% CF T/R	H 3
R156	A10265-15011	1.5 KOHM .25W 1% MF T/R	D 3
R157	A10266-4712	470. OHM .5W 5% CF T/R	F 1
R162	A10265-16221	16.2 KOHM .25W 1 MF T/R	D 2
R163	A10265-49931	499KOHM .25W 1% MF T/R	F 2
R164	A10265-10031	100. KOHM .25W 1 MF T/R	F 2
R165	A10265-49921	49.9 KOHM .25W 1 MF T/R	F 1
R166	A10265-20031	200. KOHM .25W 1 MF T/R	F 2
R167	A10265-22111	2.21KOHM .25W 1% MF T/R	D 2
R168	A10265-82511	8.25KOHM .25W 1% MF T/R	C 2
R169	A10265-42211	4.22KOHM .25W 1% MF T/R	C 2
R170	A10265-25511	2.55KOHM .25W 1 MF T/R	C 2
R171	A10265-60411	6.04KOHM .25W 1 MF T/R	C 3
R172	C10613-5	1 KOHM TOP ADJUST TRIMMER T/R	C 3
R200	C 7340-0	24.0 OHM 3W 5% MF FP T/R	A 4
R201		--- NOT USED ---	C 5
R202	A10265-49911	4.99KOHM .25W 1 MF T/R	B 4
R203	A10265-49911	4.99KOHM .25W 1 MF T/R	B 4
R204	A10265-49911	4.99KOHM .25W 1 MF T/R	B 4
R205	A10265-49911	4.99KOHM .25W 1 MF T/R	B 4
R206	A10265-10021	10. KOHM .25W 1 MF T/R	B 4
R207	A10265-10021	10. KOHM .25W 1 MF T/R	B 4
R208		--- NOT USED ---	F 4
R209	A10266-3031	30. KOHM .25W 5 CF T/R	E 4
R210	A10266-6841	680 KOHM .25W 5% CF T/R	G 5
R212	A10266-2411	240 OHM .25W 5% CF T/R	G 5
R213	A10266-3941	390. KOHM .25W 5 CF T/R	E 4
R214	A10266-9131	91. KOHM .25W 5 CF T/R	E 4
R216	A10266-1021	1.0 KOHM .25W 5% CF T/R	E 4
R217		--- NOT USED ---	E 2
R218	A10265-14031	140K .25W 1% MF T/R	E 3
R219	A10265-14031	140K .25W 1% MF T/R	E 3
R220	A10265-10031	100. KOHM .25W 1 MF T/R	E 3
R221	A10266-1511	150. OHM .25W 5 CF T/R	E 4
R222	A10265-10031	100. KOHM .25W 1 MF T/R	E 3
R223	A10266-2032	20. KOHM .5W 5 CF T/R	G 4
R224	A10266-2041	200. KOHM .25W 5 CF T/R	G 4
R225	A10266-1551	1.5 MOHM .25W 5% CF T/R	G 3

**CROWN INTERNATIONAL INC.**

1718 WEST MISHAWAKA ROAD ELKHART, INDIANA 46517 PHONE (219) 294-8000

THESE DRAWINGS AND SPECIFICATIONS ARE THE PROPERTY OF CROWN INTERNATIONAL, INC. AND SHALL NOT BE REPRODUCED, COPIED, OR USED AS THE BASIS FOR THE MANUFACTURE OR SALE OF APPARATUS OR DEVICES WITHOUT PERMISSION.

DRAWN	JAW	03-17-99	DWG. NO.	SHEET 9 OF 12	REV
PROJ.	MD35000		101809-4		(A)



PARTS LIST			
REF DES	C. P. N.	DESCRIPTION	MAP LOC.
R226	A10265-88711	8.87KOHM .25W 1% MF T/R	B 3
R227	A10265-18721	18.7KOHM .25W 1% MF T/R	B 3
R228	A10266-8211	820. OHM .25W 5% CF T/R	G 3
R229	A10266-2211	220. OHM .25W 5 CF T/R	G 3
R230	A10265-16921	16.9 KOHM .25W 1 MF T/R	B 4
R231	A10266-3921	3.9 KOHM .25W 5% CF T/R	A 3
R233	A10266-2211	220. OHM .25W 5 CF T/R	E 2
R234	A10265-10531	105KOHM .25W 1% MF T/R	A 3
R235	A10266-1531	15. KOHM .25W 5% CF T/R	E 2
R236	A10265-19111	1.91KOHM .25W 1 MF T/R	A 4
R237	A10265-10731	107.KOHM .25W 1% MF T/R	A 2
R238	A10265-19111	1.91KOHM .25W 1 MF T/R	A 3
R239	A10266-1031	10. KOHM .25W 5% CF T/R	A 2
R240	A10266-1051	1. MOHM .25W 5% CF T/R	A 1
R241	A10265-68131	681KOHM .25W 1% MF T/R	B 1
R242	A10266-4751	4.7 MOHM .25W 5 CF T/R	H 2
R243	A10265-10031	100. KOHM .25W 1 MF T/R	B 3
R244	A10266-3941	390.KOHM .25W 5 CF T/R	H 2
R245	A10265-49931	499KOHM .25W 1% MF T/R	E 2
R246	A10266-2741	270. KOHM .25W 5% CF25 T/R	E 3
R247	A10265-49931	499KOHM .25W 1% MF T/R	B 1
R248	A10265-49931	499KOHM .25W 1% MF T/R	B 2
R249	A10266-4751	4.7 MOHM .25W 5 CF T/R	A 1
R250	A10266-3951	3.9 MOHM .25W 5% CF T/R	H 2
R251	A10266-1321	1.3 KOHM .25W 5% CF T/R	B 3
R252	A10266-2421	2.4 KOHM .25W 5% CF T/R	B 3
R253	A10265-49931	499KOHM .25W 1% MF T/R	E 2
R254	A10266-2041	200. KOHM .25W 5 CF T/R	H 2
R255	A10266-1031	10. KOHM .25W 5% CF T/R	H 2
R256	A10265-15011	1.5 KOHM .25W 1% MF T/R	B 3
R257	A10266-4712	470. OHM .5W 5% CF T/R	E 1
R262	A10265-16221	16.2 KOHM .25W 1 MF T/R	B 2
R263	A10265-49931	499KOHM .25W 1% MF T/R	E 2
R264	A10265-10031	100. KOHM .25W 1 MF T/R	E 2
R265	A10265-49921	49.9 KOHM .25W 1 MF T/R	E 1
R266	A10265-20031	200.KOHM .25W 1 MF T/R	E 2
R267	A10265-22111	2.21KOHM .25W 1% MF T/R	B 2
R268	A10265-82511	8.25KOHM .25W 1% MF T/R	A 2
R269	A10265-42211	4.22KOHM .25W 1% MF T/R	A 2
R270	A10265-25511	2.55KOHM .25W 1 MF T/R	A 2
R271	A10265-60411	6.04KOHM .25W 1 MF T/R	A 3
R272	C10613-5	1 KOHM TOP ADJUST TRIMMER T/R	B 3
S1	C 7325-1	2POLE 2POS PC SLIDE SWITCH	D 5
S2	C 7325-1	2POLE 2POS PC SLIDE SWITCH	D 5
S3		--- NOT USED ---	G 5
S100	C 7325-1	2POLE 2POS PC SLIDE SWITCH	F 5
S200	C 7325-1	2POLE 2POS PC SLIDE SWITCH	B 5

**CROWN INTERNATIONAL INC.**

1719 WEST MISHAWAKA ROAD ELKHART, INDIANA 46517 PHONE (219) 294-8000

THESE DRAWINGS AND SPECIFICATIONS ARE THE PROPERTY OF CROWN INTERNATIONAL, INC. AND SHALL NOT BE REPRODUCED, COPIED, OR USED AS THE BASIS FOR THE MANUFACTURE OR SALE OF APPARATUS OR DEVICES WITHOUT PERMISSION.

DRAWN	JAW	03-17-99	DWG. NO.	SHEET 10 OF 12	REV
PROJ.	MD35000		101809-4		(A)





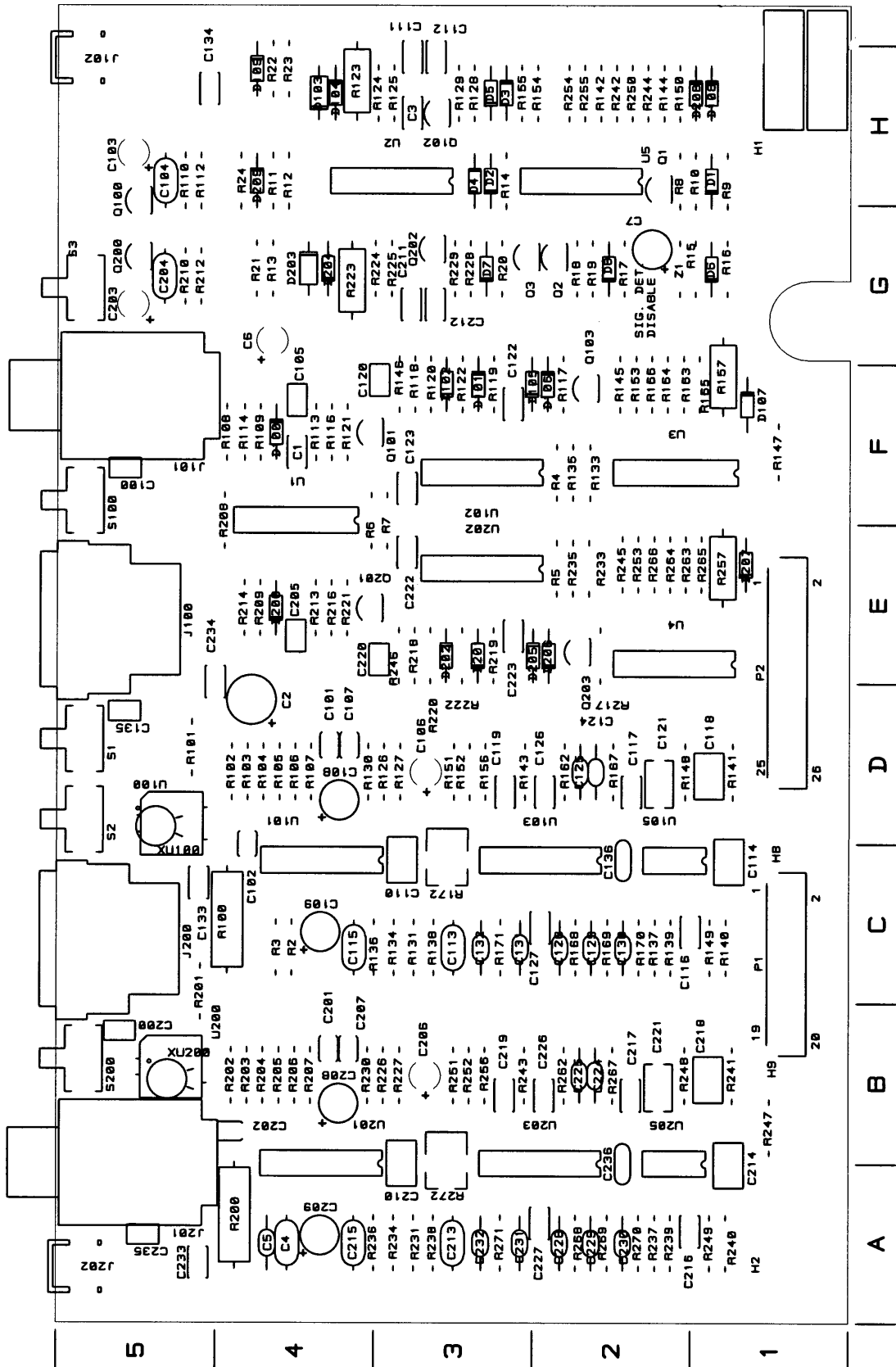

101809-4 PWA Component Map (Component Side)

E. C.	ZONE	REV.	DESCRIPTION	DATE	BY	APPROVALS			
						CHK	ME	EE	PE
		A	INITIAL RELEASE.	02-25-97	KLW				EB
		B	ADDED WIRE COLOR FOR L1 ON COMPONENT MAP. DELETED REVISION CONTROL SHEETS AND RENUMBERED REMAINING SHEETS.	03-20-97	KLW				EB

NOTES:

1. SCHEMATIC DRAWING NUMBER 101848.
2. PRINTED WIRING BOARD PART NUMBER 101849-1.
3. PRINTED WIRING ASSEMBLY PART NUMBER 101850-1.
4. THE PRINTED WIRING ASSEMBLY SHALL MEET THE IPC-A-610 CLASS 2 STANDARDS.
5. ALL LEADS SHALL BE TRIMMED TO 0.093" OR LESS.
6. POSITION COMPONENTS AS SHOWN ON COMPONENT MAP.
7. REMOVE SOLDER OR PREVENT SOLDER FROM ACCUMULATING IN HOLES INDICATED ON COMPONENT MAP.
8. THE PRINTED WIRING ASSEMBLY PART NUMBER AND DRAWING REVISION FOR THIS MODULE SHALL BE MARKED ON THE PRINTED WIRING BOARD AND SHALL BE PERMANENT.
9. INSTALL 6 OHM PTC (101103-1) INTO TO-220 TRANSISTOR HOLDER (C 8982-8) PRIOR TO INSTALLING PTC. SECURE THESE COMPONENTS TO THE PRINTED WIRING BOARD USING RTV RUBBER (S 5700-0).
10. INSTALL K2 COMMON MODE CHOKE (101868-1) INTO HOLE LOCATIONS INDICATED ON COMPONENT MAP. SECURE THIS COMPONENT TO THE PRINTED WIRING BOARD USING RTV RUBBER (S 5700-0).



CAUTION

STATIC CAN DAMAGE COMPONENTS!

DO NOT HANDLE

UNLESS WRIST STRAP IS WORN

THESE DRAWINGS AND SPECIFICATIONS ARE THE PROPERTY OF CROWN INTERNATIONAL, INC. AND SHALL NOT BE REPRODUCED, COPIED, OR USED AS THE BASIS FOR THE MANUFACTURE OR SALE OF APPARATUS OR DEVICES WITHOUT PERMISSION.

CROWN INTERNATIONAL INC.									
PRINTS TO		1718 WEST MISHAWAKA ROAD ELKHART, INDIANA 46517				PHONE (219) 294-8000			
K		PWA, CONTROL "K" SERIES CE				TOL. UNLESS SPECIFIED X.XX = ± 0.020 X.XXX = ± 0.010 DRILLS = ± 0.003			
		DRAWN	KLW	02-25-97	APPROVED BY:		DO NOT SCALE PRINT		
		CHECKED		ME			SUPERSEDES		
		SCALE		NONE		EE	E. C. N.		
		PROJ	MD350D0		PE	EB	02-25-97	C. P. N. SHEET 1 OF 4	REV
		NEXT ASSEMBLY				101850		B	



# COMPONENT MAP

(COMPONENT SIDE VIEW)

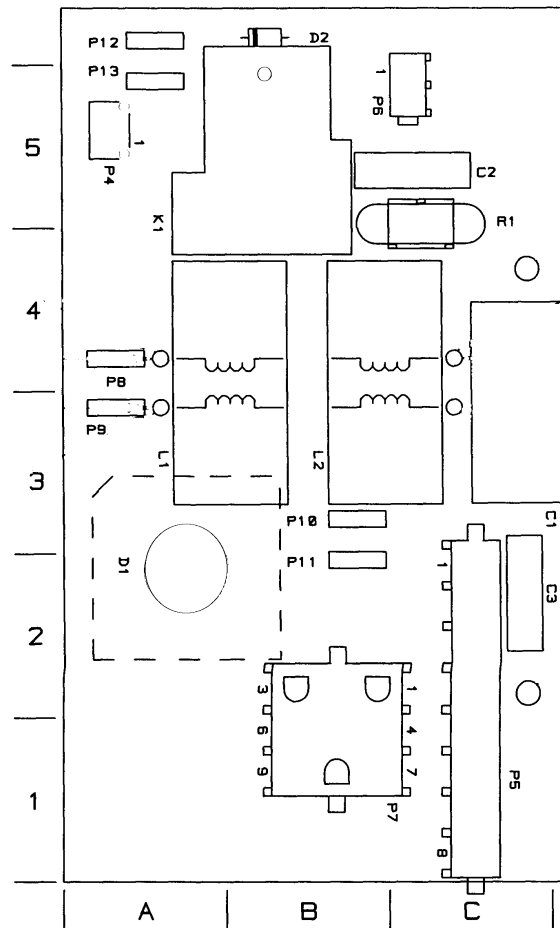

<b>CROWN INTERNATIONAL INC.</b>				
171B WEST MISHAWAKA RD. ELKHART, INDIANA 46517 PHONE (219)294-8000				
THESE DRAWINGS AND SPECIFICATIONS ARE THE PROPERTY OF CROWN INTERNATIONAL, INC. AND SHALL NOT BE REPRODUCED, COPIED, OR USED AS THE BASIS FOR THE MANUFACTURE OR SALE OF APPARATUS OR DEVICES WITHOUT PERMISSION.	DRAWN	KLW	02-25-97	DWG. NO.
	PROJ.	MD350D0		101850
				SHEET 4 OF 4
				REV (B)

NOTES:

1. SCHEMATIC DRAWING NUMBER 100442.
2. PRINTED WIRING BOARD PART NUMBER 100443-2.
3. PRINTED WIRING ASSEMBLY PART NUMBER 101865-1.

**CROWN INTERNATIONAL INC.**

1718 WEST MISHAWAKA ROAD ELKHART, INDIANA 46517 PHONE (219) 294-8000

THESE DRAWINGS AND SPECIFICATIONS ARE THE PROPERTY OF CROWN INTERNATIONAL, INC. AND SHALL NOT BE REPRODUCED, COPIED, OR USED AS THE BASIS FOR THE MANUFACTURE OR SALE OF APPARATUS OR DEVICES WITHOUT PERMISSION.

DRAWN	KLW	02-26-97	DWG. NO.	SHEET 3	REV
PROJ.	D350		101865	CONT. ON SHEET 4	(B)



PARTS LIST			
REF DES	C. P. N.	DESCRIPTION	MAP LOC.
C1	C10225-8	.47UF 250V 10% MTL POLY VERT	A 3
C2	C10225-8	.47UF 250V 10% MTL POLY VERT	B 3
C3	C10516-0	470 UF 10V 20% LOW ESR RDL T/R	B 4
C4	C10225-8	.47UF 250V 10% MTL POLY VERT	B 2
C5		--- NOT USED ---	B 5
C6	C10225-8	.47UF 250V 10% MTL POLY VERT	A 5
C7		--- NOT USED ---	A 5
C8	C10225-8	.47UF 250V 10% MTL POLY VERT	A 4
D1		--- INSTALLED ON NEXT ASSEMBL	A 2
D2		--- INSTALLED ON NEXT ASSEMBL	A 5
D3	C 2851-1	RECTIFIER, 1N4004 SILICON T/R	A 1
D4	C 2851-1	RECTIFIER, 1N4004 SILICON T/R	B 1
HW1	100847-1	PC BD SUPPORT .562" , , ,	A 1
P3	C10596-2	MATE-N-LOK MINI 24POS VERT HDR	A 1
P11	101031-1	.250 FASTON, AUTO INSERTABLE	A 1
P12	101031-1	.250 FASTON, AUTO INSERTABLE	B 2
P13	101031-1	.250 FASTON, AUTO INSERTABLE	B 1
R1	A10266-1041	100. KOHM .25W 5% CF25 T/R	A 1

CROWN INTERNATIONAL INC.

1718 WEST MISHAWAKA ROAD ELKHART, INDIANA 46517 PHONE (219) 294-8000

THESE DRAWINGS AND SPECIFICATIONS ARE THE PROPERTY OF CROWN INTERNATIONAL, INC. AND SHALL NOT BE REPRODUCED, COPIED, OR USED AS THE BASIS FOR THE MANUFACTURE OR SALE OF APPARATUS OR DEVICES WITHOUT PERMISSION.

DRAWN	KLW	02-26-97	DWG. NO.	101865	SHEET 5	REV
PROJ.	D350				CONT. ON SHEET 6	(B)

Downloaded from www.Manualslib.com manuals search engine

# COMPONENT MAP

(COMPONENT SIDE VIEW)

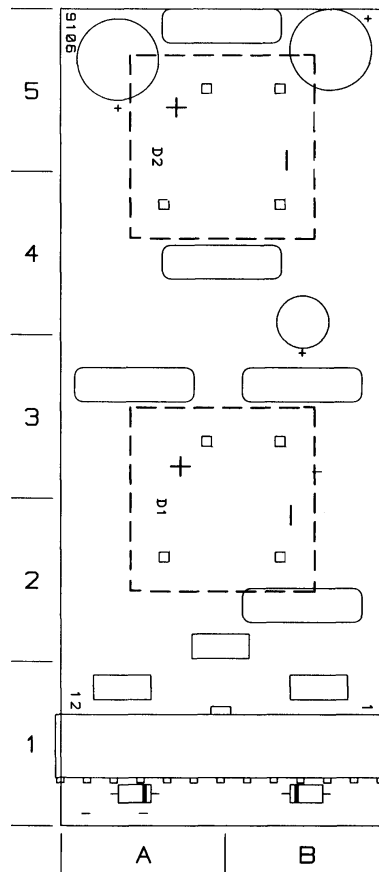

<b>CROWN INTERNATIONAL INC.</b>				
1718 WEST MISHAWAKA RD. ELKHART, INDIANA 46517 PHONE (219)294-8000				
THESE DRAWINGS AND SPECIFICATIONS ARE THE PROPERTY OF CROWN INTERNATIONAL, INC. AND SHALL NOT BE REPRODUCED, COPIED, OR USED AS THE BASIS FOR THE MANUFACTURE OR SALE OF APPARATUS OR DEVICES WITHOUT PERMISSION.	DRAWN	KLW	02-26-97	DWG. NO.
	PROJ.	D350		101865
			SHEET 6	REV <b>(B)</b>

E.C.	ZONE	REV.	DESCRIPTION	DATE	BY	APPROVALS			
						CHK	ME	EE	PE
		A	INITIAL RELEASE OF 102176-1.	04-18-97	KLW				JW
S00479		B	INITIAL RELEASE OF 102176-2. NOTE 2 WAS 100437-2, NOTE 3 WAS 102176-1	11-03-97	KLW	JAW			JY
S00479		C	ADDED NOTES 10 AND 11.	02-13-98	JAW	KLW			JY

NOTES:

1. SCHEMATIC DRAWING NUMBER 102195.
2. PRINTED WIRING BOARD PART NUMBER 100437-3.
3. PRINTED WIRING ASSEMBLY PART NUMBER 102176-2.



CAUTION

STATIC CAN DAMAGE COMPONENTS!

DO NOT HANDLE

UNLESS WRIST STRAP IS WORN

THESE DRAWINGS AND SPECIFICATIONS ARE THE PROPERTY OF CROWN INTERNATIONAL, INC. AND SHALL NOT BE REPRODUCED, COPIED, OR USED AS THE BASIS FOR THE MANUFACTURE OR SALE OF APPARATUS OR DEVICES WITHOUT PERMISSION.

CROWN INTERNATIONAL INC.									
PRINTS TO		1718 WEST MISHAWAKA ROAD ELKHART, INDIANA 46517				PHONE (219) 294-8000			
K	PWA, OUTPUT K1					TOL. UNLESS SPECIFIED X.XX = ± 0.020 X.XXX = ± 0.010 DRILLS = ± 0.003			
	DRAWN	KLW	04-18-97	APPROVED BY:		DO NOT SCALE PRINT			
	CHECKED			ME		SUPERSEDES 101795-1			
	SCALE	NONE		EE		E. C. N.			
	PROJ	MD35050		PE	JW	4-18-97	C.P.N. SHEET 1 OF 6		REV
	NEXT ASSEMBLY					102176		Ⓢ	



PARTS LIST			
REF DES	C. P. N.	DESCRIPTION	MAP LOC.
C01	C10208-4	100.UF 25V 20% RAD ELECT T/R	A 2
C02	C10208-4	100.UF 25V 20% RAD ELECT T/R	A 2
C03	C10208-4	100.UF 25V 20% RAD ELECT T/R	A 2
C04	C10208-4	100.UF 25V 20% RAD ELECT T/R	A 2
C05	C 6804-6	.1UF 50V AXIAL CER T/R 104	B 2
C06	C 6804-6	.1UF 50V AXIAL CER T/R 104	B 2
C07	C 6804-6	.1UF 50V AXIAL CER T/R 104	B 1
C08	C 6804-6	.1UF 50V AXIAL CER T/R 104	B 1
C09	C10208-4	100.UF 25V 20% RAD ELECT T/R	B 2
C10	C10238-1	330.PF 500V MIN 10% CER DISK	A 1
C11	C10238-1	330.PF 500V MIN 10% CER DISK	C 1
C12	A10434-473JD	.047UF 250VDC 5% MET POLY T/A	E 2
C13	A10434-104JD	.1UF 250V 5% MTL POLY FILM T/A	F 3
C14	A10434-103JD	.01UF 250V 5%MTL POLY FILM T/A	A 1
C15	A10434-103JD	.01UF 250V 5%MTL POLY FILM T/A	A 1
C16	A10434-103JD	.01UF 250V 5%MTL POLY FILM T/A	A 1
C17	C 8963-8	0.47 UF 250V 5% MET POLY	A 2
C18	A10434-103JD	.01UF 250V 5%MTL POLY FILM T/A	C 1
C19	A10434-103JD	.01UF 250V 5%MTL POLY FILM T/A	C 1
C20	A10434-103JD	.01UF 250V 5%MTL POLY FILM T/A	C 1
C21	C 8963-8	0.47 UF 250V 5% MET POLY	C 2
C22	D 8917-3	8200UF 110VDC ELECTROLYTIC	D 2
C23		--- NOT USED ---	B 3
C24		--- NOT USED ---	B 3
C55	C 6804-6	.1UF 50V AXIAL CER T/R 104	H 2
C57	C 6804-6	.1UF 50V AXIAL CER T/R 104	G 1
C58	C 6804-6	.1UF 50V AXIAL CER T/R 104	H 1
C59	C10208-4	100.UF 25V 20% RAD ELECT T/R	G 2
C60	C10238-1	330.PF 500V MIN 10% CER DISK	I 1
C61	C10238-1	330.PF 500V MIN 10% CER DISK	F 1
C62	A10434-473JD	.047UF 250VDC 5% MET POLY T/A	E 2
C64	A10434-103JD	.01UF 250V 5%MTL POLY FILM T/A	H 1
C65	A10434-103JD	.01UF 250V 5%MTL POLY FILM T/A	H 1
C66	A10434-103JD	.01UF 250V 5%MTL POLY FILM T/A	H 1
C67	C 8963-8	0.47 UF 250V 5% MET POLY	H 2
C68	A10434-103JD	.01UF 250V 5%MTL POLY FILM T/A	G 1
C69	A10434-103JD	.01UF 250V 5%MTL POLY FILM T/A	G 1
C70	A10434-103JD	.01UF 250V 5%MTL POLY FILM T/A	G 1
C71	C 8963-8	0.47 UF 250V 5% MET POLY	G 2
C72	D 8917-3	8200UF 110VDC ELECTROLYTIC	E 2
C73		--- NOT USED ---	G 2
C74		--- NOT USED ---	G 3
D01	C10463-5	DIODE, ULTRAFAST MUR120 T/R	A 2
D02	C10463-5	DIODE, ULTRAFAST MUR120 T/R	A 2
D03	D 9053-6	DIODE, 300V ULTRAFAST TO-220	B 1
D04	D 9053-6	DIODE, 300V ULTRAFAST TO-220	B 1
D05	C 8158-5	DIODE, SWITCHING 1SS244T T/R	F 2

**CROWN INTERNATIONAL INC.**

1718 WEST MISHAWAKA ROAD ELKHART, INDIANA 46517 PHONE (219) 294-8000

THESE DRAWINGS AND SPECIFICATIONS ARE THE PROPERTY OF CROWN INTERNATIONAL, INC. AND SHALL NOT BE REPRODUCED, COPIED, OR USED AS THE BASIS FOR THE MANUFACTURE OR SALE OF APPARATUS OR DEVICES WITHOUT PERMISSION.

DRAWN KLV 04-18-97 DWG. NO. SHEET 3 OF 6 REV

PROJ. MD35050 102176



PARTS LIST			
REF DES	C.P.N.	DESCRIPTION	MAP LOC.
D53	D 9053-6	DIODE, 300V ULTRAFAST TO-220	G 1
D54	D 9053-6	DIODE, 300V ULTRAFAST TO-220	H 1
L51	C10214-2	CHOKE, 100UH 20%	H 2
NTC01	C10215-9	NTC, THERMISTOR 20KOHM @25DEGC	E 1
P3	C10274-6	16POS MINI MATE-N-LOK VERT HDR	E 3
P01	C10273-8	16 PIN HDR PICOFLEX TIN	B 2
Q01		--- NOT USED ---	A 1
Q02	C10207-6	MOSFET, 250V 16A MTP16N25E	A 1
Q03	C10207-6	MOSFET, 250V 16A MTP16N25E	C 1
Q04	C10207-6	MOSFET, 250V 16A MTP16N25E	C 1
Q51	C10207-6	MOSFET, 250V 16A MTP16N25E	F 1
Q52	C10207-6	MOSFET, 250V 16A MTP16N25E	G 1
Q53	C10207-6	MOSFET, 250V 16A MTP16N25E	H 1
Q54		--- NOT USED ---	I 1
R01		--- NOT USED ---	A 1
R02	C10448-6	10.0HM .25W 5% FU/FP T/R	A 1
R03	C10448-6	10.0HM .25W 5% FU/FP T/R	B 1
R04	C10448-6	10.0HM .25W 5% FU/FP T/R	C 1
R05	A10266-1511	150. OHM .25W 5 CF T/R	B 3
R06	A10266-1511	150. OHM .25W 5 CF T/R	B 3
R07	A10266-1021	1.0 KOHM .25W 5% CF T/R	B 2
R08	C 9588-2	15. OHM 3W 5% MF FP	A 2
R09	C 9588-2	15. OHM 3W 5% MF FP	C 2
R10	100115-1	91. 2W, 5%, MF, 1W BODY	G 3
R11	100115-1	91. 2W, 5%, MF, 1W BODY	G 3
R12	100115-1	91. 2W, 5%, MF, 1W BODY	G 3
R13	102177-1	.054 OHM 5W 3% WW VERT MNT	D 3
R14	102177-1	.054 OHM 5W 3% WW VERT MNT	D 2
R15	C10449-4	2.7OHM .25W 5% MF T/R	A 2
R16	C10449-4	2.7OHM .25W 5% MF T/R	A 2
R17	C10449-4	2.7OHM .25W 5% MF T/R	A 2
R18	C10449-4	2.7OHM .25W 5% MF T/R	A 2
R19	C10449-4	2.7OHM .25W 5% MF T/R	C 2
R20	C10449-4	2.7OHM .25W 5% MF T/R	C 2
R21	C10449-4	2.7OHM .25W 5% MF T/R	C 2
R22	C10449-4	2.7OHM .25W 5% MF T/R	C 2
R23	A10266-5R61	5.6 OHM .25W 5% CF T/R	D 3
R24	A10266-5R61	5.6 OHM .25W 5% CF T/R	D 3
R25	C10447-8	100.KOHM HORZ ADJ TRIMMER T/R	C 3
R51	C10448-6	10.OHM .25W 5% FU/FP T/R	G 1
R52	C10448-6	10.OHM .25W 5% FU/FP T/R	G 1
R53	C10448-6	10.OHM .25W 5% FU/FP T/R	H 1
R54		--- NOT USED ---	H 1
R55	A10266-1511	150. OHM .25W 5 CF T/R	G 2
R56	A10266-1511	150. OHM .25W 5 CF T/R	G 3

<b>CROWN INTERNATIONAL INC.</b>			
1718 WEST MISHAWAKA ROAD		ELKHART, INDIANA 46517	PHONE (219) 294-8000
THESE DRAWINGS AND SPECIFICATIONS ARE THE PROPERTY OF CROWN INTERNATIONAL, INC. AND SHALL NOT BE REPRODUCED, COPIED, OR USED AS THE BASIS FOR THE MANUFACTURE OR SALE OF APPARATUS OR DEVICES WITHOUT PERMISSION.	DRAWN	KLW 04-18-97	DWG. NO.
	PROJ.	MD350S0	102176
			SHEET 4 OF 6
			REV <b>C</b>



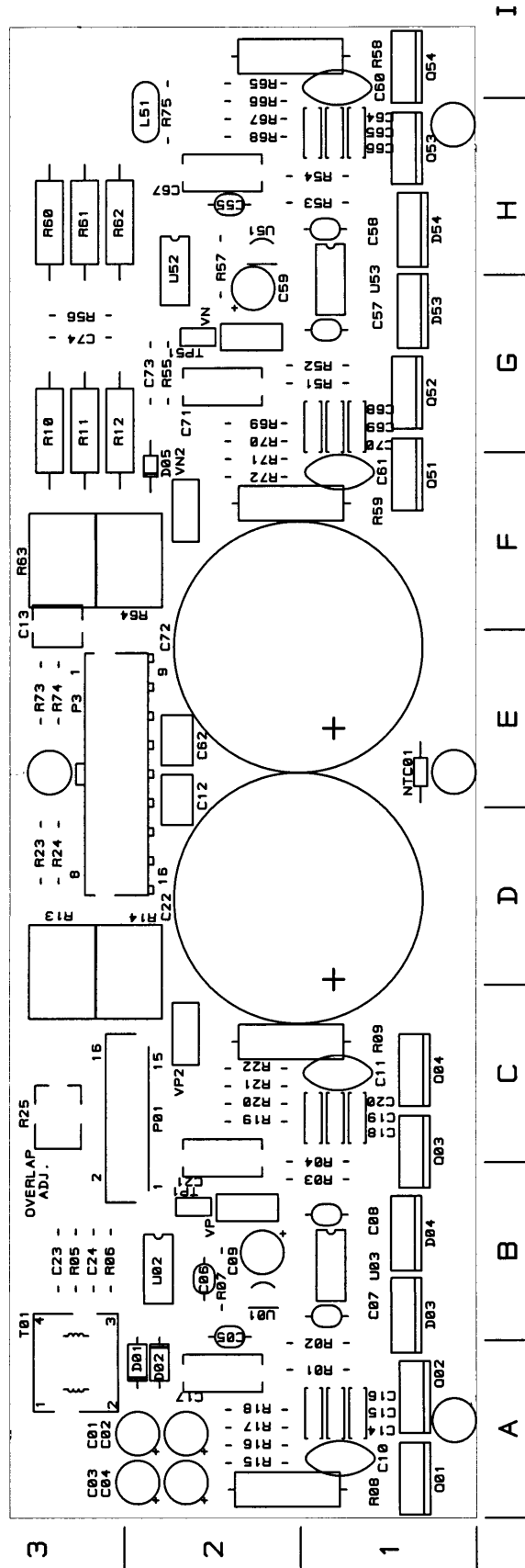

102176-2 PWA Component Map (Component Side of Module)

E. C.	ZONE	REV.	DESCRIPTION	DATE	BY	APPROVALS			
						CHK	ME	EE	PE
		A	INITIAL RELEASE OF 102175-1.	04-18-97	KLW				JW
500479		B	INITIAL RELEASE OF 101554-2. ADDED A10098-6. 102777-2 WAS D 8952-0, 102176-2 WAS 102176-1, A12148-70606 WAS 101161-1, NOTE 4 WAS 102175-1.	11-03-97	KLW	JAW			JW

NOTES:

1. APPLY RTV RUBBER (S 5700-0) TO NTC01 ON OUTPUT BOARD TO MAKE A THERMAL CONNECTION BETWEEN NTC01 AND HEATSINK (100527-1).
2. ON THE 20UH INDUCTORS, THE OUTSIDE COILS LEAD SHOULD BE CONNECTED TO THE VP2 OR VN2 CONNECTOR. THE INSIDE COILS LEAD SHOULD BE CONNECTED TO THE VP OR VN.
3. APPLY RTV RUBBER (S 5700-0) TO C12 AND C72 ON OUTPUT ASSEMBLY TO SECURE C12 AND C72 TO THE HEATSINK (100527-1).
4. THE ASSEMBLY PART NUMBER (102175-2) SHALL BE MARKED ON THE ASSEMBLY AND SHALL BE PERMANENT.

PARTS LIST			
C. P. N.	DESCRIPTION	QTY	REFERENCE DESIGNATION
A10098-6	#6 BELLEVILLE WASHER SS	9	
A12148-70606	6-32 X .375 PAN HD T15 BZ	11	
D 8958-7	INS. CERAMIC .90 X .75 X.040	3	
H43507-5	INDUCTOR, 20UH 40A MATCHED P	1	
S 2162-6	TYPE 340 HEATSINK COMPOUND	0	
S 5700-0	732 RTV RUBBER 10.3 OZ CLEAR	0	
100527-1	HEATSINK, D350 MAIN	1	
102176-2	PWA. OUTPUT K1	1	
102777-2	CLIP, K SERIES FET	2	

THESE DRAWINGS AND SPECIFICATIONS ARE THE PROPERTY OF CROWN INTERNATIONAL, INC. AND SHALL NOT BE REPRODUCED, COPIED, OR USED AS THE BASIS FOR THE MANUFACTURE OR SALE OF APPARATUS OR DEVICES WITHOUT PERMISSION.

PRINTS TO		1718 WEST MISHAWAKA ROAD ELKHART, INDIANA 46517		PHONE (219) 294-8000	
K		CROWN INTERNATIONAL INC.			TOL. UNLESS SPECIFIED
		OTPT, K1 PWA W/HS			X. XX - ± 0.020
		DRAWN KLW 04-18-97			X. XXX - ± 0.010
		APPROVED BY:			DRILLS - ± 0.003
		CHECKED	ME	DO NOT SCALE PRINT	
		SCALE	NONE	SUPERSEDES	
		PROJ	MD35050	EE	E. C. N.
		NEXT ASSEMBLY			PE JW 4-18-97
					C. P. N. 102175
					REV (B)

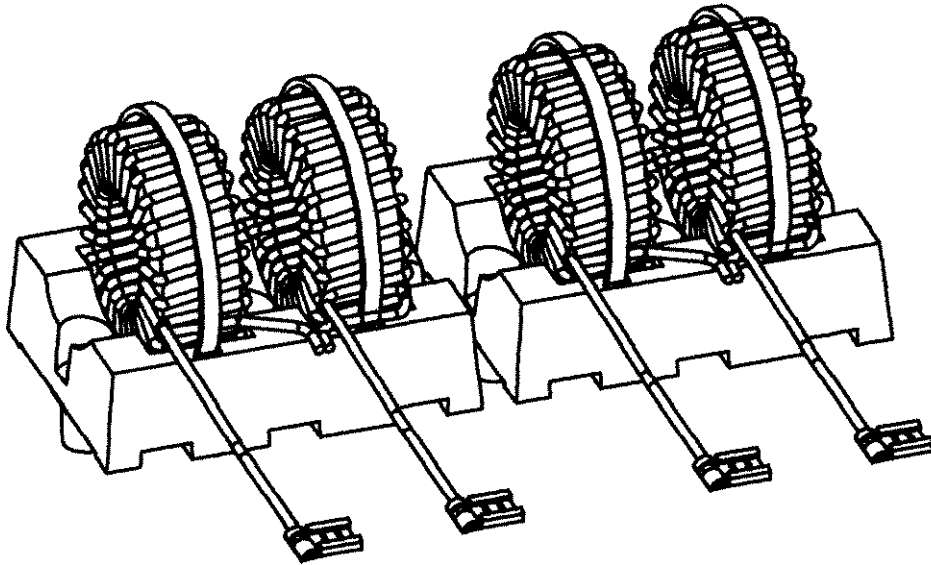

*View of Inductor Pair, CPN H43507-5, for Output Assembly CPN 102175-2*

E.C.N.	ZONE	REV.	DESCRIPTION	DATE	BY	APPROVALS			
						CHK	ME	EE	PE
		A	INITIAL RELEASE OF 102552-1.	05-14-97	KLW				JW
500508		B	ADDED NOTE 8. ADDED CPN 102088-1.	02-17-98	JAW				JW

NOTES:

1. SCHEMATIC DRAWING NUMBER 102550.
2. PRINTED WIRING BOARD PART NUMBER 102551-1.
3. PRINTED WIRING ASSEMBLY PART NUMBER 102552-1.
4. THE PRINTED WIRING ASSEMBLY SHALL MEET THE IPC-A-610 CLASS 2 STANDARDS.
5. ALL LEADS SHALL BE TRIMMED TO 0.093" OR LESS.
6. POSITION COMPONENTS AS SHOWN ON COMPONENT MAP.
7. THE PRINTED WIRING ASSEMBLY PART NUMBER AND DRAWING REVISION FOR THIS ASSEMBLY SHALL BE MARKED ON THE PRINTED WIRING BOARD AND SHALL BE PERMANENT. SEE COMPONENT MAP.
8. INSTALL FOAM ISOLATOR (102088-1) OVER LED'S (SEE COMPONENT MAP).

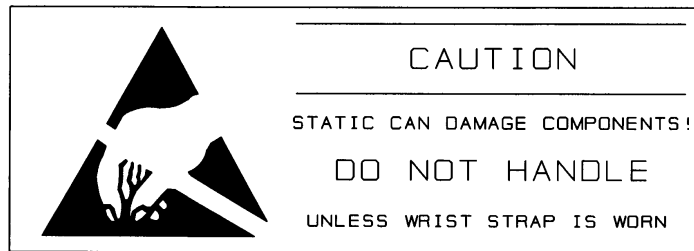

THESE DRAWINGS AND SPECIFICATIONS ARE THE PROPERTY OF CROWN INTERNATIONAL, INC. AND SHALL NOT BE REPRODUCED, COPIED, OR USED AS THE BASIS FOR THE MANUFACTURE OR SALE OF APPARATUS OR DEVICES WITHOUT PERMISSION.

PRINTS TO		CROWN INTERNATIONAL INC.				1718 WEST MISHAWAKA ROAD ELKHART, INDIANA 46517		PHONE (219) 294-8000		
K		PWA, DISPLAY "K" SERIES				TOL. UNLESS SPECIFIED X.XX - ± 0.020 X.XXX - ± 0.010 DRILLS - ± 0.003				
		DRAWN	KLW	05-14-97	APPROVED BY:	DO NOT SCALE PRINT				
		CHECKED			ME	SUPERSEDES Q43449-0				
		SCALE	NONE		EE	E.C.N.				
		PROJ #	MD350D0		PE	JW	05-14-97	C.P.N.	SHEET 1 OF 4	REV
		NEXT ASSEMBLY				102552			(B)	



PARTS LIST			
REF DES	C.P.N.	DESCRIPTION	MAP LOC.
E1	D 9117-9	LED, T 1.75 GREEN T/R	D 2
E100	D 9119-5	LED, T 1.75 AMBER T/R	B 2
E101	D 9117-9	LED, T 1.75 GREEN T/R	B 2
E102	D 9118-7	LED, T 1.75 YELLOW T/R	B 1
E103	D 9116-1	LED, T 1.75 RED T/R	B 1
E200	D 9119-5	LED, T 1.75 AMBER T/R	B 2
E201	D 9117-9	LED, T 1.75 GREEN T/R	B 2
E202	D 9118-7	LED, T 1.75 YELLOW T/R	B 1
E203	D 9116-1	LED, T 1.75 RED T/R	B 1
J1	D 8967-8	CBL, D350 INPUT	A 1
R100	C10245-6	5KOHM LNR 31 DETENT VERT PC	A 1
R200	C10245-6	5KOHM LNR 31 DETENT VERT PC	C 1
	102088-1	ISOLATOR, "K" SERIES FOAM LED	SEE MAP

**CROWN INTERNATIONAL INC.**  
 1718 WEST MISHAWAKA RD. ELKHART, INDIANA 46517 PHONE (219)294-8000

THESE DRAWINGS AND SPECIFICATIONS ARE THE PROPERTY OF CROWN INTERNATIONAL, INC. AND SHALL NOT BE REPRODUCED, COPIED, OR USED AS THE BASIS FOR THE MANUFACTURE OR SALE OF APPARATUS OR DEVICES WITHOUT PERMISSION.

SCALE	NONE	DWG. NO. 102552	SHEET 3 OF 4	REV (B)
PROJ #	MD35000			

Downloaded from [www.Manualslib.com](http://www.Manualslib.com) manuals search engine



# COMPONENT MAP

(COMPONENT SIDE VIEW)

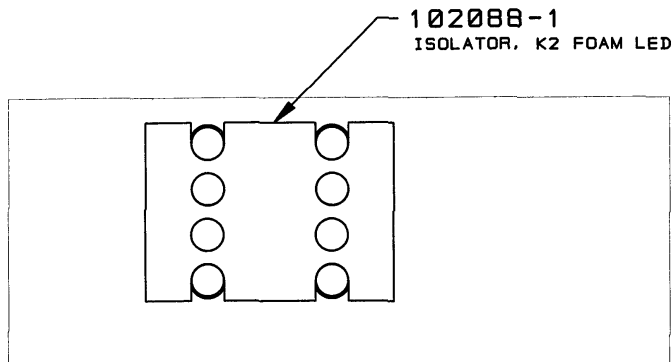
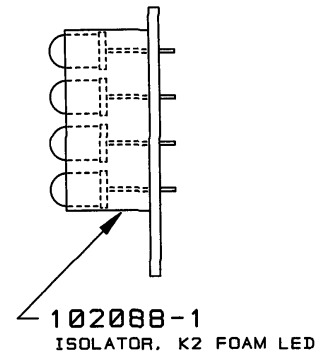
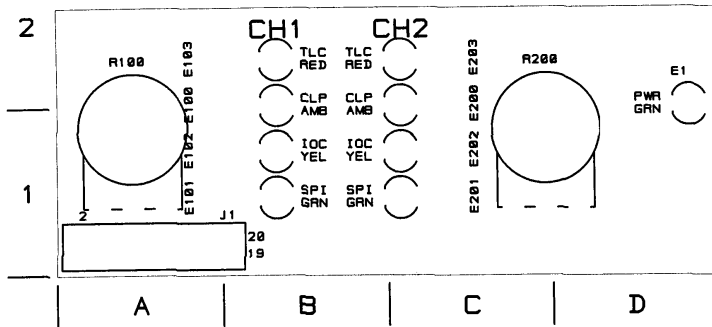

<b>CROWN INTERNATIONAL INC.</b>				
1718 WEST MISHAWAKA RD. ELKHART, INDIANA 46517 PHONE (219)294-8000				
SCALE	NONE	C. P. N.	SHEET 4 OF 4	REV
PROJ #	MD35000	102552		(B)

This Page Intentionally Left Blank

---

## 10 Schematic Diagrams

---

The schematics referenced and provided are representative only. There may be slight variations between amplifier to amplifier. These schematics are intended to be used for troubleshooting purposes only.

[100436 Rev D](#)

[100442 Rev C](#)

[100495 Rev G](#)

[100522 Rev M](#)

[101012 Rev B](#)

[101848 Rev B](#)

[101946 Rev F](#)

[102195 Rev C](#)

[102550 Rev A](#)

This Page Intentionally Left Blank